

MODEL # C2X-E - HFS

SPECIFICATIONS

The Excel Series C2X-E family provides quick, easy shopping access and can merchandise a wide variety of refrigerated foods. Ideal for grab-n-go meals or other high margin prepared food selections such as sandwiches, prepared salads, pizza, etc.



Available lengths: 51 3/8" 75 3/8" 99 3/8" 147 1/2"

Available depths: 42"

Available heights: 55 3/4"



UNIT SHOWN WITH OPTIONAL SHELVES
AND SOLID END PANELS

STANDARD FEATURES

- DOE 2017 Compliant
- Remote Refrigeration
- All Metal Construction
- Hussmann Standard Paint & Bumper Colors
(Consult Factory for Available Colors)
- (1) Row Top Canopy Lighting
- 30 1/4" Base Deck Display
- Front Cart Bumper
- Energy Efficient Coil
- Hardwire Direct
- Listed in Accordance with UL 471
and NSF 7 Standards
- 5 Year Modular Coil Warranty
- Floor Drain Required

OPTIONAL FEATURES

- Stainless Steel Exterior Finish
- Hussmann Optional Colors
(Consult Factory for Available Colors)
- Up to (2) Rows of Optional Shelves
(Consult Factory for More Information)
- Up to (1) Additional Row of Top Canopy Lighting
(Consult Factory)
- Lighting Under Shelves
(Consult Factory for All Available Options)
- Solid End Panels
 - Right Left Both Ends
- View End Panels
 - Right Left Both Ends
- Contour End Panels
 - Right Left Both Ends
- Solid End Panels with Mirrored Interior
(Consult Factory for Additional Information)
- E-Plus (EP) Extra-High Efficiency Coil
(Reduces Energy Costs by 18%)

MODEL # C2X-E - HFS

REMOTE - REFRIGERATED

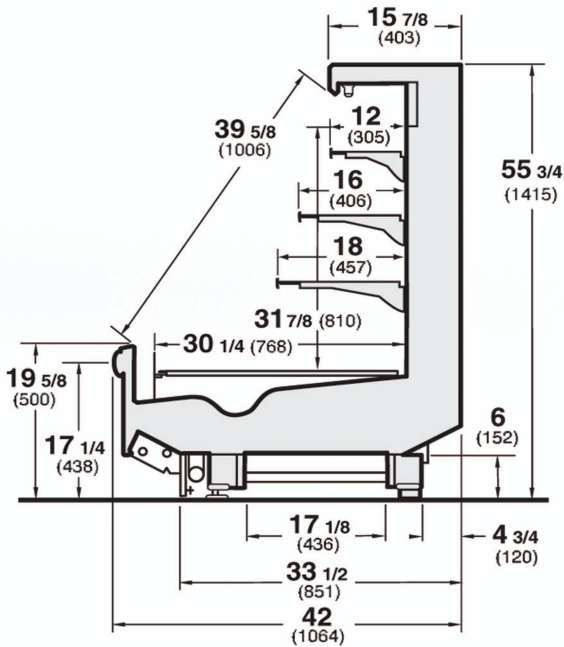

MODEL	L*	D	H	BTU/HR**	VOLTS	AMPS	EVAP. TEMP °F***	PLUG	WT	REFRIG.
C2X-4'E-HFS	51 3/8	42	55 3/4	2376	120-230	20	26	Hardwire	600	Verify
C2X-8'E-HFS	99 3/8	42	55 3/4	4752	120-230	20	26	Hardwire	1000	Verify
C2X-12'E-HFS	147 1/2	42	55 3/4	7128	120-230	20	26	Hardwire	1200	Verify

REMOTE - REFRIGERATED (MEAT)

MODEL	L*	D	H	BTU/HR	VOLTS	AMPS	EVAP. TEMP °F	PLUG	WT	REFRIG.
C2X-4'E-HFS	51 3/8	42	55 3/4	2496	120-230	20	23	Hardwire	600	Verify
C2X-8'E-HFS	99 3/8	42	55 3/4	4992	120-230	20	23	Hardwire	1000	Verify
C2X-12'E-HFS	147 1/2	42	55 3/4	7488	120-230	20	23	Hardwire	1200	Verify

* LENGTHS INCLUDE END PANELS

** BTU/HR FOR DAIRY, DELI, PRODUCE

*** EVAP. TEMP FOR DAIRY, DELI, PRODUCE

Note: Please use Hussmann's technical data sheets to get precise dimensions for all store layout purposes.

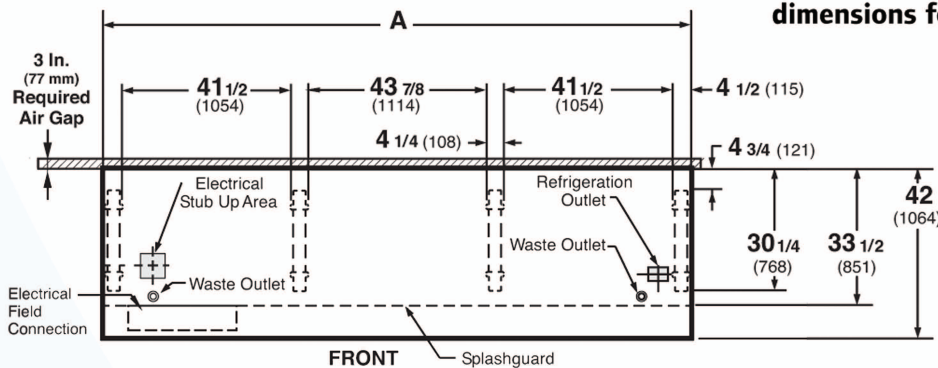

Electrical & Plumbing locations

Dimension	8 FT	12 FT
A	96 3/8 (2448)	144 1/2 (3670)

Notes:

Case-to-case electrical connections are made in front of splashguard.

Overall case length without ends or partitions.



Conforms to UL Standard 471, and NSF Standard 7; Certified To CSA Standard C22.2 No.120



Hussmann refrigerated merchandisers configured for sale for use in the United States meet or surpass the requirements of the DOE 2017 energy efficiency standards

1. For optimum performance, these models are designed for use in air-conditioned stores where temperature and humidity are maintained at 75°F and 55% R.H. Locate case away from direct sunlight, rapid air currents and extreme temperature changes. Case is designed for holding pre-chilled product only.

RPI in line with its current policy reserves the right to change or revise specifications and product design in connection with any feature of our products. Such changes do not entitle the buyer to corresponding changes improvements, additions, or replacements for equipment previously sold or shipped.

CALL TOLL FREE: 800-525-3692 (609-714-2330)

FAX: 609-714-2331 www.rpiindustries.com

220 ROUTE 70, MEDFORD, NJ 08055