

MODEL # D5XRRI - HFS

SPECIFICATIONS

The Excel Series D5XRRI provides the unique benefit of being stocked from the rear using roll-in milk racks. The case is attached to a walk-in cooler, so the milk doesn't leave its refrigerated environment during stocking. Curtains are used behind the milk to reduce air currents and shield the walk-in storage from view.



Available lengths: 75 3/8" 99 3/8" 147 1/2"

Available depths: 46 1/2"

Available heights: 85 3/4"



UNIT SHOWN WITH ROLL-IN MILK RACKS
AND OPTIONAL SOLID END PANELS

STANDARD FEATURES

- DOE 2017 Compliant
- Remote Refrigeration
- All Metal Construction
- Hussmann Standard Paint & Bumper Colors
(Consult Factory for Available Colors)
- (1) Row Top Canopy Lighting
- Designed for use with Roll-in Milk Racks
- Open Rear Access to Walk-In Cooler
- Front Cart Bumper
- Energy Efficient Coil
- Hardwire Direct
- Listed in Accordance with UL 471
and NSF7 Standards
- 5 Year Modular Coil Warranty
- Floor Drain Required

OPTIONAL FEATURES

- Stainless Steel Exterior Finish
- Hussmann Optional Colors
(Consult Factory for Available Colors)
- Solid End Panels
 - Right Left Both Ends
- Integrated Night Curtain

MODEL # D5XRRI - HFS

REMOTE - REFRIGERATED

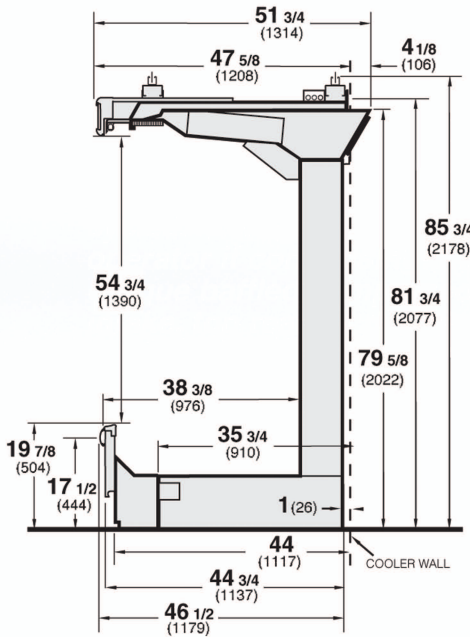

MODEL	L*	D	H	BTU / HR**	VOLTS	AMPS	EVAP. TEMP °F	PLUG	WT	REFRIG.
D5X-6RRI-HFS	75 3/8	46 1/2	85 3/4	6780	120	20	21	Hardwire	900	Verify
D5X-8RRI-HFS	99 3/8	46 1/2	85 3/4	9040	120	20	21	Hardwire	1000	Verify
D5X-12RRI-HFS	147 1/2	46 1/2	85 3/4	13560	120	20	21	Hardwire	1400	Verify

* LENGTHS INCLUDE END PANELS

** ADD 10 BTU / HR PER SHELF ROW FOR LED LIGHT FIXTURES

** ADD 20 BTU / HR PER SHELF ROW FOR LED LIGHT FIXTURES

Note: Please use Hussmann's technical data sheets to get precise dimensions for all store layout purposes.



Rear of case with curtains

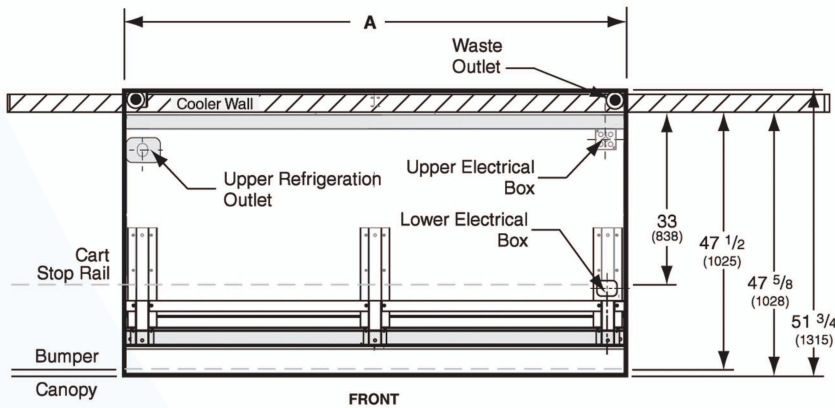

Electrical & Plumbing locations

Dimension	8 FT	12 FT
A	96 3/8 (2448)	144 1/2 (3670)

Notes:

Each end and insulated partition adds 1 1/2" (38 mm) to the length of the lineup.

Overall case length without ends or partitions.



Conforms to UL Standard 471, and NSF Standard 7; Certified To CSA Standard C22.2 No.120



Hussmann refrigerated merchandisers configured for sale for use in the United States meet or surpass the requirements of the DOE 2017 energy efficiency standards

1. For optimum performance, these models are designed for use in air-conditioned stores where temperature and humidity are maintained at 75°F and 55% R.H. Locate case away from direct sunlight, rapid air currents and extreme temperature changes. Case is designed for holding pre-chilled product only.

RPI in line with its current policy reserves the right to change or revise specifications and product design in connection with any feature of our products. Such changes do not entitle the buyer to corresponding changes improvements, additions, or replacements for equipment previously sold or shipped.

CALL TOLL FREE: 800-525-3692 (609-714-2330)

FAX: 609-714-2331 www.rpiindustries.com

220 ROUTE 70, MEDFORD, NJ 08055