

MODEL # DSRPI-03 - HFS

SPECIFICATIONS

The Specialty Series DSRPI-03 Island Produce Display offers flexible merchandising built to your produce department's requirements for center divider and product height. In addition, we can supply flat racks or multi level steps. Custom panels can be added to match your store's produce department design.

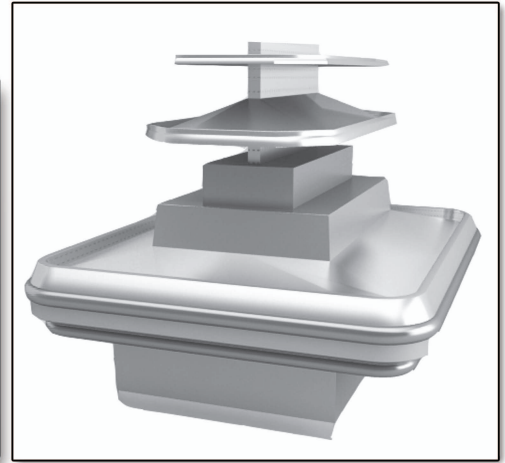

Available lengths: 98 1/4" 122 1/4" 146 1/4" 170 1/4" 194 1/4"
 218 1/4" 242 1/4" 266 1/4" 290 1/4"

Available depths: 74 5/8"

Available heights: 69"



STANDARD FEATURES

- DOE 2017 Compliant
- Remote Refrigeration
- Low Center Divider - 8" Aluminum
- Impact Body Styles
- Green Epoxy Flat Wire Racks
- Painted Exterior
- Urethane Deck Non-Insulated (Dry)
- Plastic Product Dividers Every 24"
- Price Tag Wire with Chrome Posts
- 3" Black Vinyl Cart Bumpers (Impact Style)
- Insulated Urethane Interior (Refrigerated)
- Package-Type Forced Air Coil (Refrigerated)
- Solar Digital Thermometer (Refrigerated)
- Please Reference Color Chart for Choice of Standard Hussmann Paint and Finish Options
- ETL Listed / ETL Sanitation Listed Environmentally Safe Refrigerant

OPTIONAL FEATURES

- Ledge Lights
Green Epoxy Step Wire Racks with Plastic Product Dividers Every 24"
- Scale Hangers (Single/Double)
- Adjustable Stainless Steel Shelves (14", 16" Non-Refrigerated)
- Bag Dispensers
- Price Tag Molding
- Solid Urethane-Coated Fixed Steps (dry)
- Additional Product Dividers
- Water Outlets with Quick Disconnect (Refrigerated)
- Water Spray Hose (Refrigerated)
- Custom Decor
- High Center Divider (24", 30", 38")
- 5' Wide Case
- Custom Exterior Lengths and Body Panel Options (Consult Your Hussmann Sales Representative)

NOTE: Does not hold processed produce or juice temperatures.

MODEL # DSRPI-03 - HFS

REMOTE - REFRIGERATED

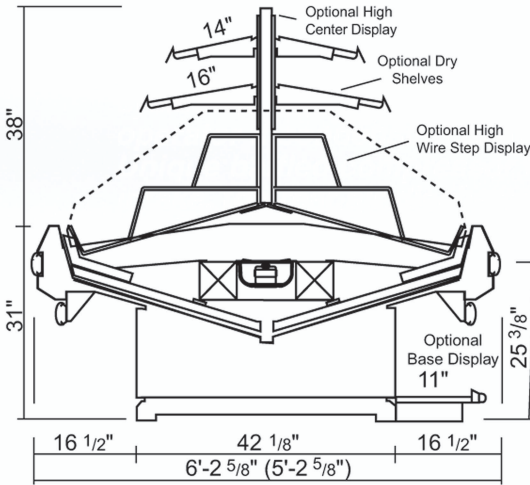

DSRPI-03
Shelf & Rack Option

MODEL	L*	D	H	BTU / HR	VOLTS	AMPS**	EVAP. TEMP °F	PLUG	WT	REFRIG.
DSRPI-03-8'-HFS	98 1/4"	74 5/8"	69"	6920	120	0.60	18	Hardwire	1300	Verify
DSRPI-03-10'-HFS	122 1/4"	74 5/8"	69"	8650	120	0.90	18	Hardwire	1625	Verify
DSRPI-03-12'-HFS	146 1/4"	74 5/8"	69"	10380	120	1.20	18	Hardwire	1950	Verify
DSRPI-03-14'-HFS	170 1/4"	74 5/8"	69"	12110	120	1.50	18	Hardwire	2275	Verify
DSRPI-03-16'-HFS	194 1/4"	74 5/8"	69"	13840	120	1.80	18	Hardwire	2600	Verify
DSRPI-03-18'-HFS	218 1/4"	74 5/8"	69"	15570	120	2.10	18	Hardwire	2925	Verify
DSRPI-03-20'-HFS	242 1/4"	74 5/8"	69"	17300	120	2.40	18	Hardwire	3250	Verify
DSRPI-03-22'-HFS	266 1/4"	74 5/8"	69"	19030	120	2.70	18	Hardwire	3575	Verify
DSRPI-03-24'-HFS	290 1/4"	74 5/8"	69"	20760	120	3.00	18	Hardwire	3900	Verify

* LENGTHS INCLUDE END PANELS

** AMPS FOR FANS ONLY. CONSULT FACTORY FOR ADDITIONAL INFORMATION

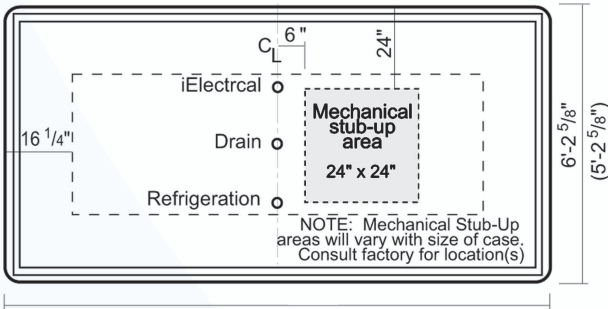

VARIABLE LENGTHS

Electrical & Plumbing locations



Conforms to UL Standard 471,
and NSF Standard 7; Certified
To CSA Standard C22.2 No.120



Hussmann refrigerated merchandisers configured for sale for use in the United States meet or surpass the requirements of the DOE 2017 energy efficiency standards

- For optimum performance, these merchandisers are designed for use in stores where ambient temperatures and humidity do not exceed 75 Degrees Fahrenheit and 55% R.H. Locate away from direct sunlight, rapid air currents and extreme temperature changes. Exposure to air currents from ceiling fans, air conditioning diffusers, ovens, etc. will disrupt the case air curtain and refrigerated zone. Refrigerated Displays are designed to maintain pre-chilled products. Adding or loading warm products above 41 Degrees Fahrenheit can affect the temperature in the entire cabinet.

RPI in line with its current policy reserves the right to change or revise specifications and product design in connection with any feature of our products. Such changes do not entitle the buyer to corresponding changes improvements, additions, or replacements for equipment previously sold or shipped.

CALL TOLL FREE: 800-525-3692 (609-714-2330)

FAX: 609-714-2331 www.rpiindustries.com

220 ROUTE 70, MEDFORD, NJ 08055