

MODEL # GSVM 60 INCH TALL - HFS

SPECIFICATIONS

The Specialty Series GSVM places maximum attention on merchandising. The narrow canopy and plexiglass side panels increase product visibility. All GSVM merchandisers have the same contour and line up together to create extended product displays.



Available lengths: 40"

Available depths: 30 5/8"

Available heights: 60"



STANDARD FEATURES

- DOE 2017 Compliant
- Self-Contained Refrigeration
- Remote Refrigeration
- End Cap Spot Display
- Canopy and Shelf Lighting
- Slide-Out Condensing Unit
- 5 Year Modular Coil Warranty
- Two Positioned Lighted Cantilever Shelves
- Front Air Intake and Discharge
- Adjustable Temperature Control
- Electric Condensate Evaporator Pan
- 2" Black Vinyl Cart Bumper
- Black Splash Guard
- Solar Digital Thermometer
- UL Listed & UL ANSI / NSF 7 Certified
- Environmentally Safe Refrigerant

OPTIONAL FEATURES

- Additional Shelving
- Choice of Exterior Colors
- Wrap-Around Bumper
- Stainless Steel Exterior
- Legs
- Nightcover
- Remote Application
- Cross Bar and Hook Display
- Casters
- Locking Security Cover

MODEL # GSVM 60 INCH TALL - HFS

SELF - CONTAINED

MODEL	L	D	H	HP	VOLTS	AMPS	PLUG	WT	REFRIG.
GSVM-4060-HFS	40	30 5/8	60	3/4	115	20	5-20P	380	134A

REMOTE - REFRIGERATED

MODEL	L	D	H	BTU/HR	VOLTS	AMPS	EVAP. TEMP °F	PLUG	WT	REFRIG.
GSVM-4060-HFS	40	30 5/8	60	4410	115	20	36	Hardwire	308	Verify

Clearance required. Refer to installation instructions.

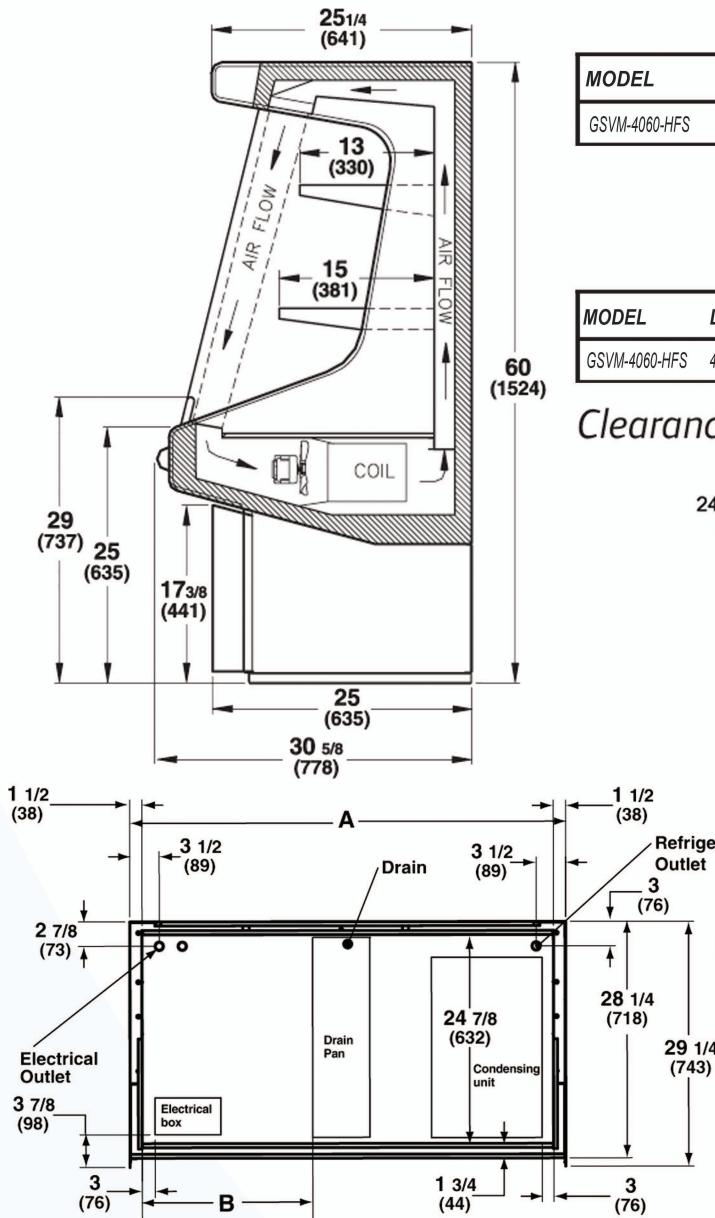

Electrical & Plumbing locations

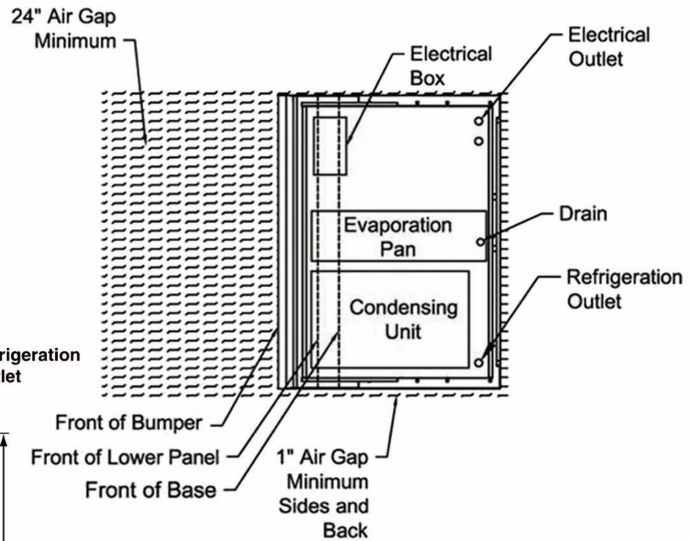

Conforms to UL Standard 471, and NSF Standard 7; Certified To CSA Standard C22.2 No.120



Hussmann refrigerated merchandisers configured for sale for use in the United States meet or surpass the requirements of the DOE 2017 energy efficiency standards

- For optimum performance, these merchandisers are designed for use in stores where ambient temperatures and humidity do not exceed 75 Degrees Fahrenheit and 55% R.H. Locate away from direct sunlight, rapid air currents and extreme temperature changes. Exposure to air currents from ceiling fans, air conditioning diffusers, ovens, etc. will disrupt the case air curtain and refrigerated zone. Refrigerated Displays are designed to maintain pre-chilled products. Adding or loading warm products above 41 Degrees Fahrenheit can affect the temperature in the entire cabinet.

RPI in line with its current policy reserves the right to change or revise specifications and product design in connection with any feature of our products. Such changes do not entitle the buyer to corresponding changes improvements, additions, or replacements for equipment previously sold or shipped.

CALL TOLL FREE: 800-525-3692 (609-714-2330)

FAX: 609-714-2331 www.rpiindustries.com

220 ROUTE 70, MEDFORD, NJ 08055