

MODEL # ISFGG-HFS

SPECIFICATIONS

The Self-Select Series ISFGG is a variant of the ISMGG specializing in frozen foods. Dual temperature kit changes the merchandiser to medium temperature and comes with special degrees celsius control for the thermometer. Unit is available with R404A refrigerant, one inch dial thermometer, electronic controls with digital display, and telescoping bottom wire shelves.



Available lengths: 68 3/8" 132"

Available depths: 41 1/2"

Available heights: 37 3/8"



STANDARD FEATURES

- DOE 2017 Compliant
- Self-Contained Refrigeration
- White Powder Coated Interior Paint
- Black Upper and Lower Impact Bumpers
- One Inch Dial Thermometer
- Electronic Controls With Digital Display
- Telescoping Bottom Wire Shelves
- Adjustable Temperature Control
- Expansion Valve with Filter Kit
- Condensate Evaporator Pan (Self-Contained Only)
- Tested per NSF Type II Ambient Conditions (80°F/60% RH)
- UL Listed & UL ANSI / NSF 7 Certified
- Environmentally Safe Refrigerant

OPTIONAL FEATURES

- Dual Temperature Kit Changes Merchandiser to Medium Temperature
- Variety of Color Options for Bumper and Décor Panels
- Stainless Steel Exterior
- High Humidity Condensate Pan Kit (N/A on Remote Refrigerated Units)
- Price Tag Moulding
- Duplex Receptacle Kit
- Recessed Casters
- Two Inch Dial Thermometer
- Degree Celcius Control for Thermometer

MODEL # ISFGG-HFS

SELF - CONTAINED

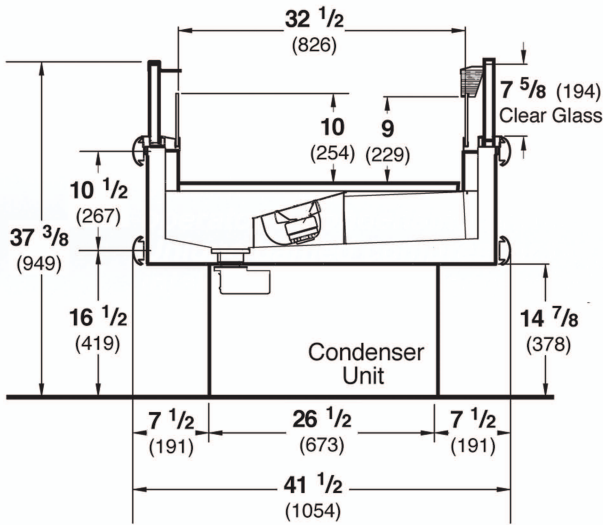

MODEL	L	D	H	HP	VOLTS	AMPS	PLUG	WT	REFRIG.
ISFGG-5-HFS	68 3/8	41 1/2	37 3/8	1.0	208-230	20	6-20P	670	404A
ISFGG-10-HFS	132	41 1/2	37 3/8	1.0x2	208-230	20x2	6-20Px2	1340	404A

Each 5-foot case section has a full 60" of interior length for product display.

Note: All 10' models have two separate refrigeration systems and the self-contained models have 2 separated power cords.* Requires field wiring.

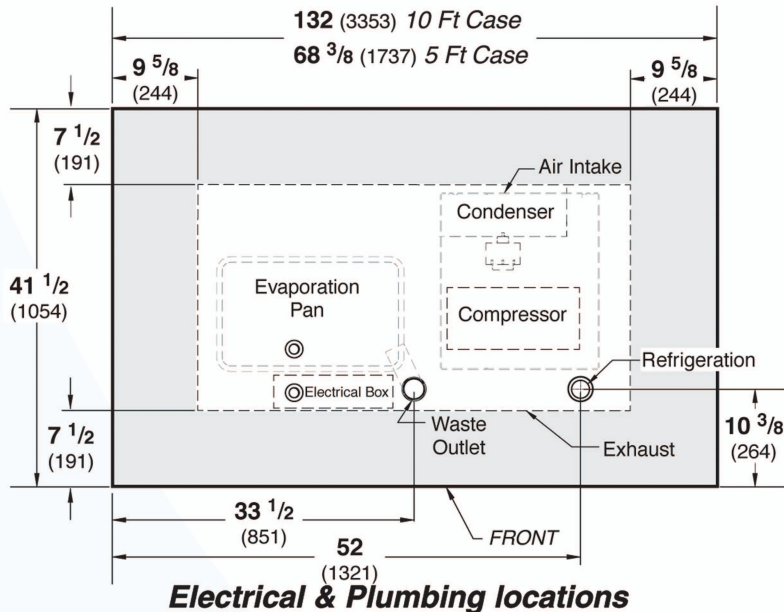

Hussmann refrigerated merchandisers configured for sale for use in the United States meet or surpass the requirements of the DOE 2017 energy efficiency standards

- For optimum performance, these merchandisers are designed for use in stores where ambient temperatures and humidity do not exceed 80 Degrees Fahrenheit and 60% R.H. Locate away from direct sunlight, rapid air currents and extreme temperature changes. Exposure to air currents from ceiling fans, air conditioning diffusers, ovens, etc. will disrupt the case air curtain and refrigerated zone. Refrigerated Displays are designed to maintain pre-chilled products. Adding or loading warm products above 41 Degrees Fahrenheit can affect the temperature in the entire cabinet.

RPI in line with its current policy reserves the right to change or revise specifications and product design in connection with any feature of our products. Such changes do not entitle the buyer to corresponding changes improvements, additions, or replacements for equipment previously sold or shipped.

CALL TOLL FREE: 800-525-3692 (609-714-2330)

FAX: 609-714-2331 www.rpiindustries.com

220 ROUTE 70, MEDFORD, NJ 08055