

## MODEL # NAV / NAVC-HFS

### SPECIFICATIONS

The Self-Select Series NAV / NAVC is a self-contained merchandiser designed specifically for deli product display. Unit is available with a number of different options to satisfy customer needs, and features physical qualities that allow for extended product display time! Units available in straight (NAV) or optional curved profile (NAVC).



Available lengths:  51 5/16"  75 5/16"  99 5/16"

Available depths:  35 1/2"

Available heights:  46 15/16"  46 7/8" (NAVC)



Conforms to NSF-STD 7  
**TYPE II**

DOE 2017  
Energy Efficiency  
Compliant

NAV (STRAIGHT PROFILE)  
UNIT SHOWN

### STANDARD FEATURES

- DOE 2017 Compliant
- Self-Contained Refrigeration
- Large Tempered Glass Front and Interior Upper and Lower Fluorescent Lamps Provide Maximum Product Visibility
- Front Bumper is Standard in Black, Red Front Bumper Available Upon Request
- Full Size Rear Glass Sliding Doors Provide Viewing and Easy Access to Displayed Product
- One Row 13" and One Row 16" Wired Upper Mezzanine Shelves
- NAV and NAVC Standard White Painted interior and Exterior, NAV-SS and NAVC-SS with Stainless Steel Interior and Exterior
- Stainless Steel Models Utilize High Quality Stainless Steel with Mirrored Interior Ends
- Standard 1" Leveling Pods Assist with Installation (2) Casters are Provided with Each Merchandiser and May Be Installed in place of the Leveling Pods
- Gravity Coil Increases Product Integrity for a Longer Display Time
- Exterior Rear Receptacle with 3 Amp Fuse Supplied for Connecting a Scale to Rear of Case
- Interior Case Thermometer
- 1" Interior Floor Drain is Piped to the Rear Case Exterior
- Standard Floor Grates Protect Case Bottom and Product Displays Placed in Lower Storage Area
- Built-in Cabinet Drain with Gas Condensate Pan for Defrost Water
- Type II (80°F/60% RH) Certified
- UL Listed & UL ANSI / NSF 7 Certified
- Environmentally Safe Refrigerant

### OPTIONAL FEATURES

- Curved Profile (NAVC)
- 6" Leg Kit
- Skirt Kit (use with leg kit)
- Extra Wire Mezzanine Shelves
- Full Size Solid Rear Doors with Mirrored Interior Panels
- Stainless Steel

CALL TOLL FREE: 800-525-3692 (609-714-2330)

FAX: 609-714-2331 [www.rpiindustries.com](http://www.rpiindustries.com)

220 ROUTE 70, MEDFORD, NJ 08055

## MODEL # NAV / NAVC-HFS

### NAV

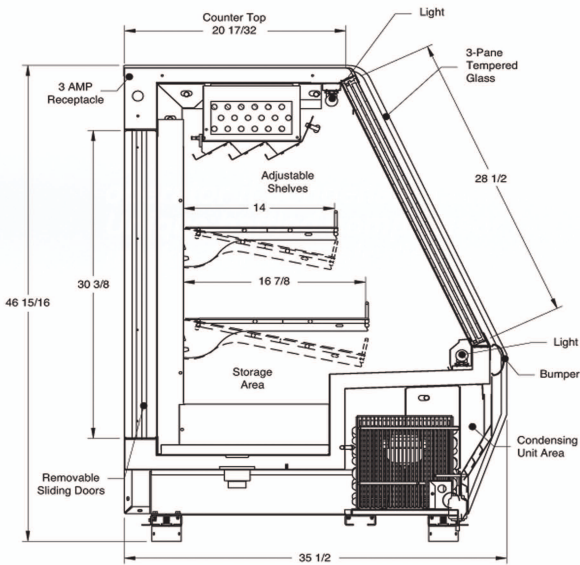

### NAVC

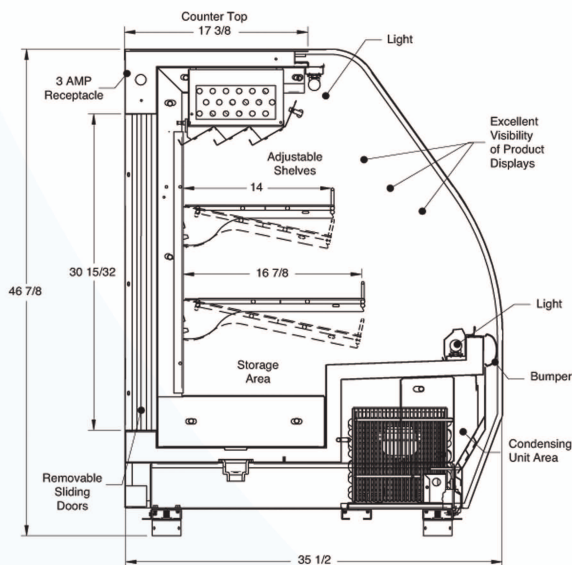

### SELF - CONTAINED (NAV)

MODEL	L	D	H	HP	VOLTS	AMPS	PLUG	WT	REFRIG.
NAV-4-HFS	51 5/16	35 1/2	46 15/16	1/3	115/60/1	9.2	5-15P	505	134A
NAV-6-HFS	75 5/16	35 1/2	46 15/16	1/3	115/60/1	12.8	5-15P	700	134A
NAV-8-HFS	99 5/16	35 1/2	46 15/16	1/2	115/60/1	15.3	5-20P	890	134A

### SELF - CONTAINED (NAVC)

MODEL	L	D	H	HP	VOLTS	AMPS	PLUG	WT	REFRIG.
NAVC-4-HFS	51 5/16	35 1/2	46 7/8	1/3	115/60/1	9.2	5-15P	505	134A
NAVC-6-HFS	75 5/16	35 1/2	46 7/8	1/3	115/60/1	12.8	5-15P	700	134A
NAVC-8-HFS	99 5/16	35 1/2	46 7/8	1/2	115/60/1	15.3	5-20P	890	134A

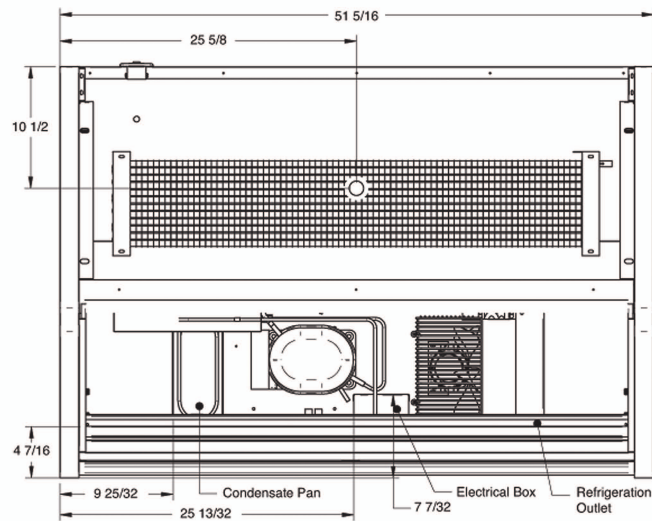

### Electrical & Plumbing locations



Conforms to UL Standard 471,  
and NSF Standard 7; Certified  
To CSA Standard C22.2 No.120



Conforms to NSF STD 7  
**TYPE II**

**DOE 2017**  
Energy Efficiency  
Compliant

Hussmann refrigerated merchandisers configured for sale for use in the United States meet or surpass the requirements of the DOE 2017 energy efficiency standards

- For optimum performance, these merchandisers are designed for use in stores where ambient temperatures and humidity do not exceed 80 Degrees Fahrenheit and 60% R.H. Locate away from direct sunlight, rapid air currents and extreme temperature changes. Exposure to air currents from ceiling fans, air conditioning diffusers, ovens, etc. will disrupt the case air curtain and refrigerated zone. Refrigerated Displays are designed to maintain pre-chilled products. Adding or loading warm products above 41 Degrees Fahrenheit can affect the temperature in the entire cabinet.

RPI in line with its current policy reserves the right to change or revise specifications and product design in connection with any feature of our products. Such changes do not entitle the buyer to corresponding changes improvements, additions, or replacements for equipment previously sold or shipped.

CALL TOLL FREE: 800-525-3692 (609-714-2330)

FAX: 609-714-2331 [www.rpiindustries.com](http://www.rpiindustries.com)

220 ROUTE 70, MEDFORD, NJ 08055