

MODEL # P1NX-E - HFS

SPECIFICATIONS

The Excel Series P1NX-E reduces the front to back dimension to save floor space.



Available lengths: 75 3/8" 99 3/8"

Available depths: 42"

Available heights: 53 3/4"



UNIT SHOWN WITH OPTIONAL
SOLID END PANELS

STANDARD FEATURES

- DOE 2017 Compliant
- Remote Refrigeration
- All Metal Construction
- Hussmann Standard Paint & Bumper Colors
(Consult Factory for Available Colors)
- Narrow Footprint Design reduces Overall
Depth to save floor space
- 25 1/4" Base Deck Display
- Front Cart Bumper
- Energy Efficient Coil
- Hardwire Direct
- Listed in Accordance with UL 471
and NSF 7 Standards
- 5 Year Modular Coil Warranty
- Floor Drain Required

OPTIONAL FEATURES

- Stainless Steel Exterior Finish
- Hussmann Optional Colors
(Consult Factory for Available Colors)
- Solid End Panels
 - Right Left Both Ends

MODEL # P1NX-E - HFS

REMOTE - REFRIGERATED

MODEL	L*	D	H	BTU / HR	VOLTS	AMPS	EVAP. TEMP °F	PLUG	WT	REFRIG.
P1NX-6'E-HFS	75 3/8	42	53 3/4	3660	120-230	20 / 15	24	Hardwire	700	Verify
P1NX-8'E-HFS	99 3/8	42	53 3/4	4880	120-230	20 / 15	24	Hardwire	900	Verify

* LENGTHS INCLUDE END PANELS

Note: Please use Hussmann's technical data sheets to get precise dimensions for all store layout purposes.

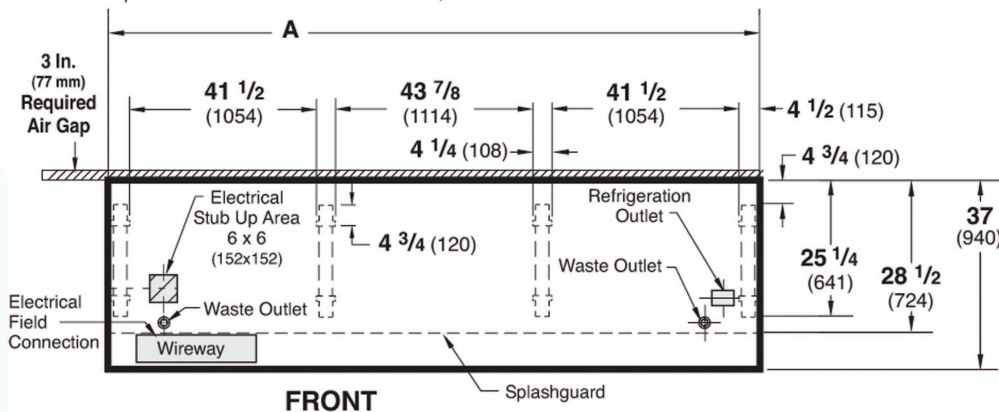
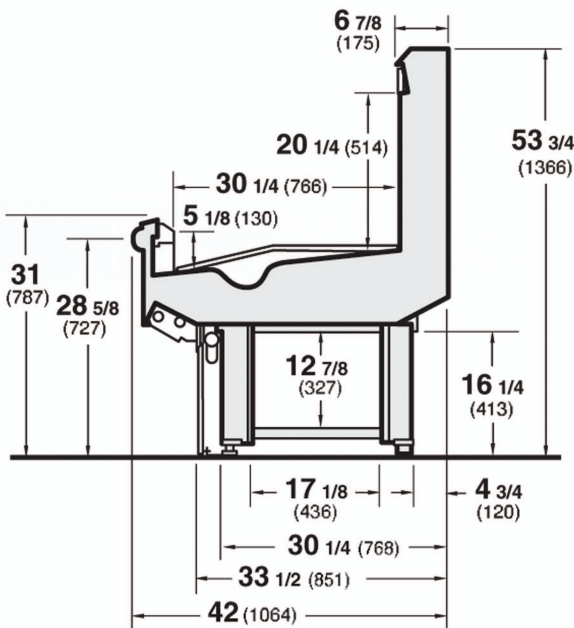

Electrical & Plumbing locations

Dimension	8 FT	12 FT
A	96 3/8 (2448)	144 1/2 (3670)

Notes:

Overall case length without ends or partitions.



Conforms to UL Standard 471, and NSF Standard 7; Certified To CSA Standard C22.2 No.120



Hussmann refrigerated merchandisers configured for sale for use in the United States meet or surpass the requirements of the DOE 2017 energy efficiency standards

1. For optimum performance, these models are designed for use in air-conditioned stores where temperature and humidity are maintained at 75°F and 55% R.H. Locate case away from direct sunlight, rapid air currents and extreme temperature changes. Case is designed for holding pre-chilled product only.

RPI in line with its current policy reserves the right to change or revise specifications and product design in connection with any feature of our products. Such changes do not entitle the buyer to corresponding changes improvements, additions, or replacements for equipment previously sold or shipped.

CALL TOLL FREE: 800-525-3692 (609-714-2330)

FAX: 609-714-2331 www.rpiindustries.com

220 ROUTE 70, MEDFORD, NJ 08055