

MODEL # Q1-DC (CURVED GLASS)-HFS

SPECIFICATIONS

The Q Series Q1-DC features enhanced product visibility with solid surface faces and unobstructed product view, along with a large rear door opening and steep angle allow for ease of access to product. The unit is designed for ease of installation, simplified glass adjustment and with special alignment parts that assure fit and do not require unsightly joint trim. These features make Q1-DC the perfect choice for Single Deck Service, displaying deli and cheese products.



Available lengths: 50 1/4" 62 1/4" 74 1/4" 98 1/4" 122 1/4" 146 1/4"

Available depths: 45"

Available heights: 46" (VARIOUS HEIGHTS AVAILABLE)

Optional wedges: 22 1/2° (I/O) 45° (I/O) 90° (Outside Only)



STANDARD FEATURES

- DOE 2017 Compliant
- Remote-Refrigeration
- Tempered, Lift-Up Curved Front Glass
- Air Sweep
- Coil Corrosion Protective Coating
- Modular Coil System (5 Year Warranty)
- Adjustable Stainless Steel Legs
- Double-Row T5 Top Light
- Snap-On Painted Lower Front Panel
- Silver Anodized Glass Hardware
- Glass Top
- Black Thermoplastic Front & Rear Ledge
- Black Vinyl Cart Bumper
- Removable Brushed Stainless Steel Interior Wall and deck
- Snap-On Stainless Steel Rear Close-Off Panel
- Solar Digital Thermometer
- Electronic Ballast
- Thermostat & Suction Stop Solenoid
- Please Reference Color Chart for Choice of Standard Hussmann Paint and Finish Options.
- ETL Listed / ETL Sanitation Listed
- Environmentally Safe Refrigerant

OPTIONAL FEATURES

- Non-Glare Glass (Excluding 45° I & 22.5° I Wedges)
- Energy Efficient LED Canopy Lighting
- 1 or 2 Step Stainless Steel Display
- Corian®, Granite or Other Solid Surface Front, Rear, and Top Ledge Surfaces (Requires NSF Approved Materials)
- Rear Doors (Mirrored or Clear Glass Only on Straight Cases)
- View or Solid Ends
- Mirror Finish Stainless Steel Inside End Panels
- Stainless Steel Mock Pedestals
- Top Mounted Scale Stand with Integrated & Communication Cables
- Ledge Lighting
- Liquid Line Shut-Off Hand Valve
- 15 Amp and GFCI Duplex Outlets
- Special Interior and Exterior Finishes
- Custom Lengths and Options*
(Consult Your Hussmann Sales Representative)

MODEL # Q1-DC (CURVED GLASS)-HFS

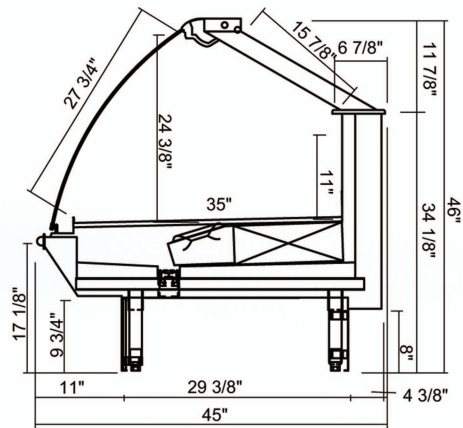

REMOTE - REFRIGERATED

MODEL	L*	D	H	BTU / HR	VOLTS	AMPS	EVAP. TEMP °F	PLUG	WT	REFRIG.
Q1-DC 4'-HFS	50 1/4	45	46	2072	120	15	20	Hardwire	700	Verify
Q1-DC 5'-HFS	62 1/4	45	46	2590	120	15	20	Hardwire	800	Verify
Q1-DC 6'-HFS	74 1/4	45	46	3108	120	15	20	Hardwire	900	Verify
Q1-DC 8'-HFS	98 1/4	45	46	4144	120	15	20	Hardwire	1100	Verify
Q1-DC 10'-HFS	122 1/4	45	46	5180	120	15	20	Hardwire	1200	Verify
Q1-DC 12'-HFS	146 1/4	45	46	6216	120	15	20	Hardwire	1300	Verify

* LENGTHS INCLUDE END PANELS

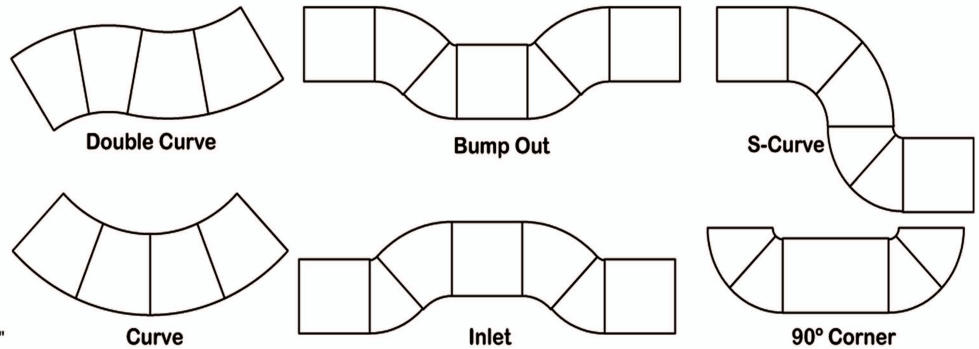
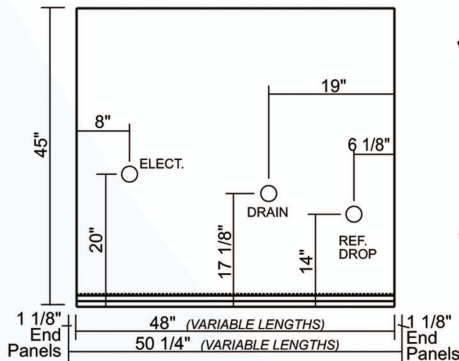
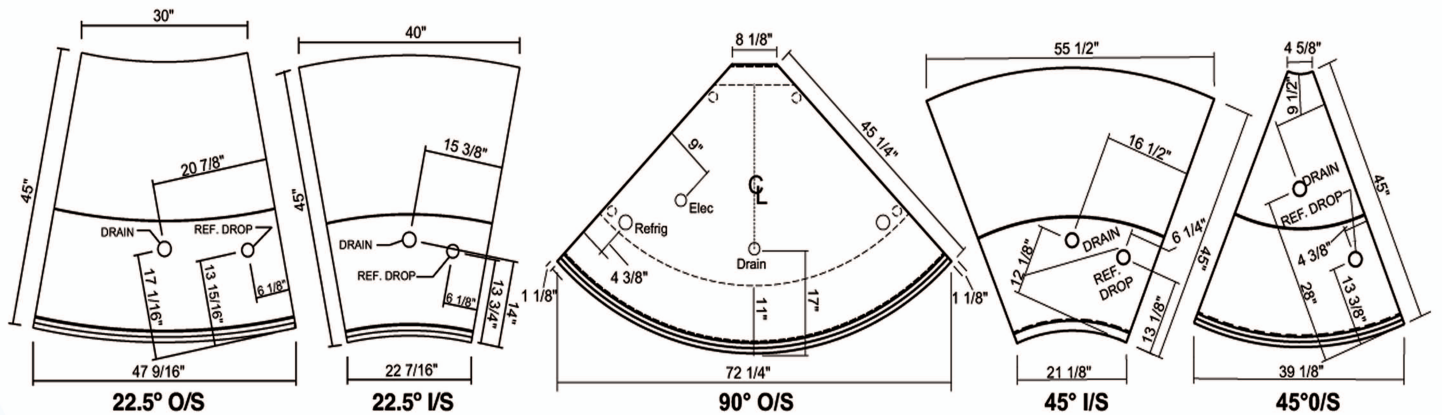

Electrical & Plumbing locations



Conforms to UL Standard 471,
and NSF Standard 7; Certified
To CSA Standard C22.2 No.120



Hussmann refrigerated merchandisers configured for sale for use in the United States meet or surpass the requirements of the DOE 2017 energy efficiency standards

1. For optimum performance, these models are designed for use in air-conditioned stores where temperature and humidity are maintained at 75°F and 55% R.H. Locate case away from direct sunlight, rapid air currents and extreme temperature changes. Case is designed for holding pre-chilled product only.

RPI in line with its current policy reserves the right to change or revise specifications and product design in connection with any feature of our products. Such changes do not entitle the buyer to corresponding changes improvements, additions, or replacements for equipment previously sold or shipped.

CALL TOLL FREE: 800-525-3692 (609-714-2330)

FAX: 609-714-2331 www.rpiindustries.com

220 ROUTE 70, MEDFORD, NJ 08055