

## MODEL # Q3-SP - HFS

### SPECIFICATIONS

The Q Series Q3-SP provides superior flexibility for both merchandising and food preparation. A three level self-service display area topped off with various options for food prep will give you a complete food production and display environment. With the Q3-SP you can prepare, merchandise and sell deli items, pizzas, salads, sushi, meals-to-go and much more! Rear storage and various prep tops are just some of the many options available.



Available lengths:  50 1/4"  62 1/4"  74 1/4"  98 1/4"  122 1/4"  146 1/4"

Available depths:  43 1/2"

Available heights:  39 1/2"

Optional wedges:  22 1/2° (I/O)  45° (I/O)  90° (Outside Only)



### STANDARD FEATURES

- DOE 2017 Compliant
- Remote-Refrigeration
- 1/2" Plexiglass Front
- Black Thermoplastic Front Ledge
- Snap-On Stainless Steel Lower Rear Panel
- Painted Front Panel
- Adjustable Stainless Steel Legs
- Straight Tempered Glass Sneeze Guard
- Black Metal Deck Pans and Internal Back Panel (Hand Removable)
- White Thermoplastic Food Prep Counter
- T-5 Canopy Light
- Solar Digital Thermometer
- 1" Black Vinyl Cart Bumper
- Please Reference Color Chart for Choice of Standard Hussmann Paint and Finish Options
- ETL Listed / ETL Sanitation Listed
- Environmentally Safe Refrigerant

### OPTIONAL FEATURES

- LED Canopy and Shelf Lighting
- Black Thermal Plastic, Corian®, Granite or Other Solid Surface Front Ledge or Food Counter Prep Top (NSF 7 Approved Material)
- 12" and 18" Adjustable Shelves (Level and 15° Tilt)
- Energy Efficient LED Case Lighting for Shelves and Canopy
- 16" Deep Refrigerated Rear Storage
- 12" Deep Dry Rear Storage
- Stainless Steel Interior
- View or Solid End Panels
- Refrigerated Condiment Area (Specify Cut-Out Requirements)
- Mirror Bright Interior End Panels
- Liquid Line Shut-Off Hand Valve
- Ledge Lighting
- Thermostat (Remote)
- Thermal Plastic Wrapping Board
- Energy Efficient Fan Motors
- Custom Trim and Décor
- Custom Lengths and Options\*  
(Consult your Hussmann Sales Representative)

## MODEL # Q3-SP - HFS

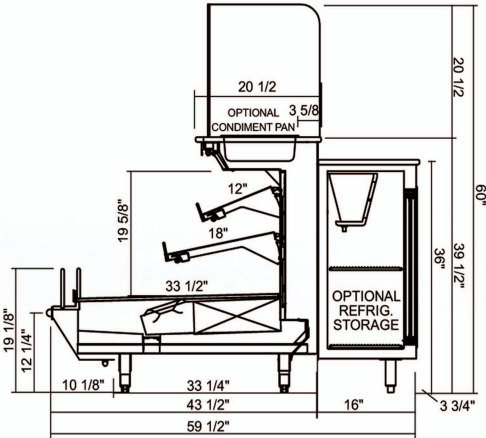

### REMOTE - REFRIGERATED

MODEL	L*	D	H	BTU/HR	VOLTS	AMPS	EVAP. TEMP °F	PLUG	WT	REFRIG.
Q3-SP 4'-HFS	50 1/4"	43 1/2"	39 1/2"	3940	120	15	20	Hardwire	600	Verify
Q3-SP 5'-HFS	62 1/4"	43 1/2"	39 1/2"	4925	120	15	20	Hardwire	800	Verify
Q3-SP 6'-HFS	74 1/4"	43 1/2"	39 1/2"	5910	120	15	20	Hardwire	900	Verify
Q3-SP 8'-HFS	98 1/4"	43 1/2"	39 1/2"	7880	120	15	20	Hardwire	1200	Verify
Q3-SP 10'-HFS	122 1/4"	43 1/2"	39 1/2"	9850	120	15	20	Hardwire	1300	Verify
Q3-SP 12'-HFS	146 1/4"	43 1/2"	39 1/2"	11820	120	15	20	Hardwire	1500	Verify

\* LENGTHS INCLUDE END PANELS

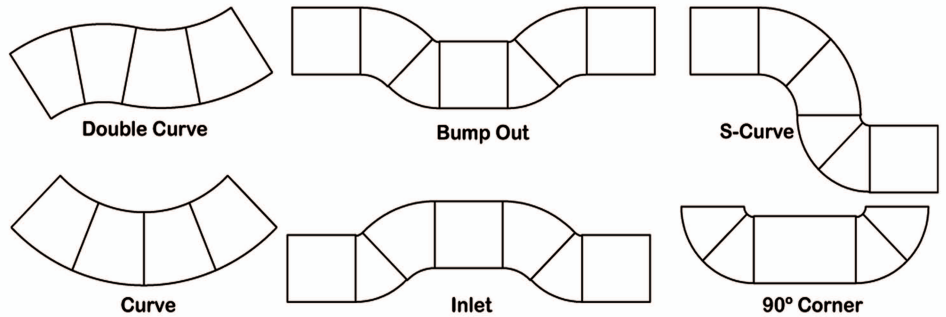
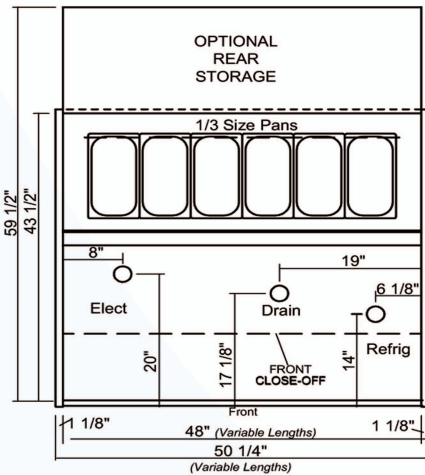
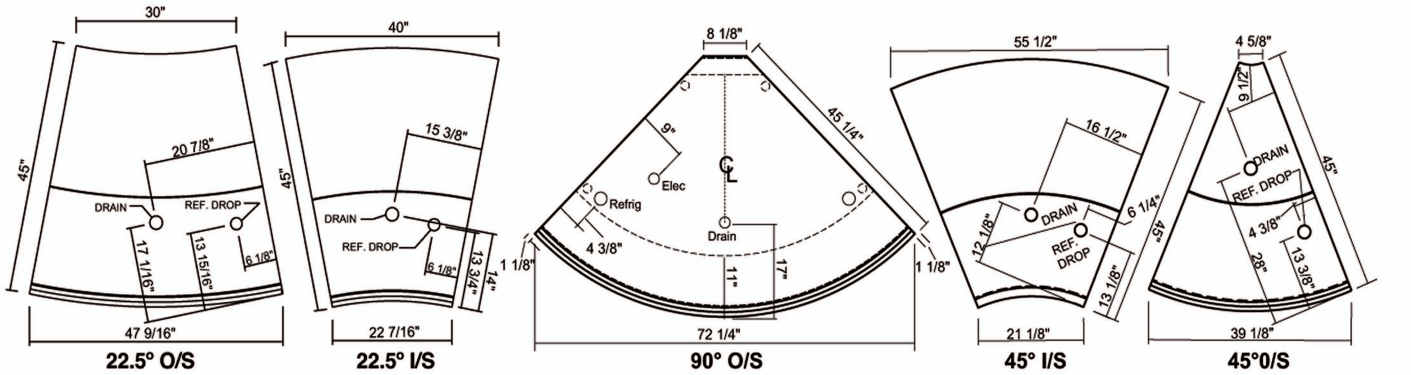

### Electrical & Plumbing locations



Conforms to UL Standard 471, and NSF Standard 7; Certified To CSA Standard C22.2 No.120



Hussmann refrigerated merchandisers configured for sale for use in the United States meet or surpass the requirements of the DOE 2017 energy efficiency standards

1. For optimum performance, these models are designed for use in air-conditioned stores where temperature and humidity are maintained at 75°F and 55% R.H. Locate case away from direct sunlight, rapid air currents and extreme temperature changes. Case is designed for holding pre-chilled product only.

RPI in line with its current policy reserves the right to change or revise specifications and product design in connection with any feature of our products. Such changes do not entitle the buyer to corresponding changes improvements, additions, or replacements for equipment previously sold or shipped.

CALL TOLL FREE: 800-525-3692 (609-714-2330)

FAX: 609-714-2331 [www.rpiindustries.com](http://www.rpiindustries.com)

220 ROUTE 70, MEDFORD, NJ 08055