

## MODEL # RGD30 (72" HIGH UNIT) - HFS

### SPECIFICATIONS

The Specialty Series RGD, or Refrigerated Gondola Display Merchandiser is a grab & go case that comes in a variety of different sizes. It is available with a number of different "Hussmann" paint and finish options, as well as a variety of shelving options.

These cases are also unique in that they can be utilized to refrigerate numerous different types of products ranging from floral, food, beverage, dairy, deli, and produce.

Units are available in Self-Contained or Remote Refrigeration



UNIT SHOWN WITH OPTIONAL VIEW ENDS & STAINLESS STEEL INTERIOR

Available lengths:  47 3/4"  50 1/4"  62 1/4"  74 1/4"

98 1/4"  122 1/4"  146 1/4"

Available depths:  30 1/4"  31" (Remote Refrigerated Only)

Available heights:  73 5/8"  85 3/8" (4' & 8' Self-Contained Only)

88 5/8" (5' & 6' Self-Contained Only)



72" TALL UNITS OFFERED WITH UP TO 4 OPTIONAL ROWS OF SHELVES

24" CLEARANCE REQUIRED BETWEEN CEILING AND TOP OF THE RGD UNITS FOR PROPER COMPRESSOR AIRFLOW

### STANDARD FEATURES

- DOE 2017 Compliant
- Remote Refrigeration
- Multi-Deck Air Curtain
- Forced Air Coil
- Black Interior
- Single Top Light SPX30 T5
- 2" Black Vinyl Cart Bumper
- Solar Digital Thermometer
- Evap Pan with Pump (Self-Contained)
- End Panels (Self-Contained)
- Condensing Unit (Self-Contained)
- Please Reference Color Chart for Choice of Standard Hussmann Paint and Finish Options
- ETL Listed / ETL Sanitation Listed
- Environmentally Safe Refrigerant

### OPTIONAL FEATURES

- Self-Contained Refrigeration
- End Panels (Solid or View End) (Remote)
- Mirror Bright Stainless Steel on Interior of End Panels
- Powder Coated Adjustable Shelf with Tag Molding and Product Stop (150lb max)
- Powder Coated Level Heavy Duty Shelves with Tag Molding (250lb max)
- T-8 Dual Canopy Lamps
- Slant Shelf for Condiment Pans
- Lights for shelves with Remote Ballast (T5)
- White or Stainless Steel interior
- Back-Lighted Sign
- Liquid Line Hand Valve
- Air Evap Pan (Remote)
- Custom Lengths, Trim, Decor and Options  
(Consult your Hussmann Sales Representative)

## MODEL # RGD30 (72" HIGH UNIT) - HFS

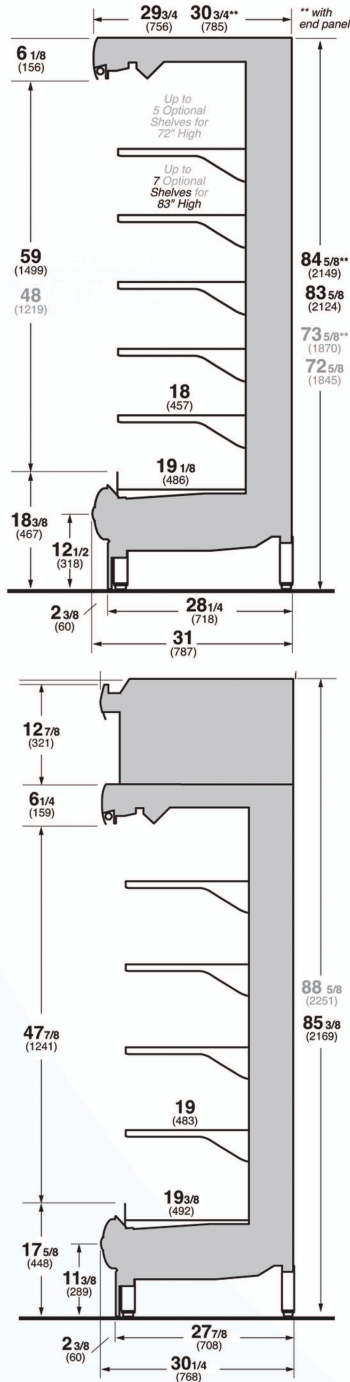

### SELF - CONTAINED

MODEL	L*	D	H	HP	VOLT	AMP	PLUG	WT	REFRIG.
RGD30-72-4-SC-HFS	50 1/4	30 1/4	85 3/8	1/2	208-240	1.33	14-30P	1100	404A
RGD30-72-5-SC-HFS	62 1/4	30 1/4	88 5/8	1/2	208-240	1.62	14-30P	1200	404A
RGD30-72-6-SC-HFS	74 1/4	30 1/4	88 5/8	3/4	208-240	1.95	14-30P	1400	404A
RDG30-72-8-SC-HFS	98 1/4	30 1/4	85 3/8	3/4	208-240	2.59	14-30P	1600	404A

### REMOTE - REFRIGERATED

MODEL	L*	D	H	BTU/HR	VOLTS	AMPS	EVAP. TEMP °F	PLUG	WT	REFRIG.
RGD30-72-3.9-HFS	47 3/4	31	73 5/8	6800	120	1.13	20	Hardwire	1100	Verify
RGD30-72-4-HFS	50 1/4	31	73 5/8	7820	120	1.33	20	Hardwire	1200	Verify
RGD30-72-5-HFS	62 1/4	31	73 5/8	9775	120	1.62	20	Hardwire	1400	Verify
RGD30-72-6-HFS	74 1/4	31	73 5/8	11730	120	1.95	20	Hardwire	1600	Verify
RDG30-72-8-HFS	98 1/4	31	73 5/8	15640	120	2.59	20	Hardwire	1800	Verify
RGD30-72-10-HFS	122 1/4	31	73 5/8	19550	120	3.24	20	Hardwire	2000	Verify
RGD30-72-12-HFS	146 1/4	31	73 5/8	23460	120	3.89	20	Hardwire	2100	Verify

\* LENGTHS INCLUDE END PANELS

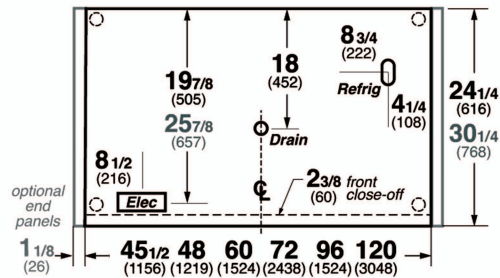

### Electrical & Plumbing locations



Conforms to UL Standard 471, and NSF Standard 7; Certified To CSA Standard C22.2 No. 120



Hussmann refrigerated merchandisers configured for sale for use in the United States meet or surpass the requirements of the DOE 2017 energy efficiency standards

- For optimum performance, these merchandisers are designed for use in stores where ambient temperatures and humidity do not exceed 75 Degrees Fahrenheit and 55% R.H. Locate away from direct sunlight, rapid air currents and extreme temperature changes. Exposure to air currents from ceiling fans, air conditioning diffusers, ovens, etc. will disrupt the case air curtain and refrigerated zone. Refrigerated Displays are designed to maintain pre-chilled products. Adding or loading warm products above 41 Degrees Fahrenheit can affect the temperature in the entire cabinet.

RPI in line with its current policy reserves the right to change or revise specifications and product design in connection with any feature of our products. Such changes do not entitle the buyer to corresponding changes improvements, additions, or replacements for equipment previously sold or shipped.

CALL TOLL FREE: 800-525-3692 (609-714-2330)

FAX: 609-714-2331 [www.rpiindustries.com](http://www.rpiindustries.com)

220 ROUTE 70, MEDFORD, NJ 08055