

MODEL # RGDC - HFS

SPECIFICATIONS

The Specialty Series RGDC, or Refrigerated Gondola Display Curved Merchandiser is a Grab N' Go case that comes in one size and is available with a number of different "Hussmann" paint and finish options. These cases are also unique in that they can be utilized to refrigerate numerous different types of products, ranging from floral, food, beverage, dairy, deli, and produce.



Available lengths: 47 3/4"

Available depths: 37 1/4"

Available heights: 72" 83" 86 1/2"

UNIT SHOWN WITH OPTIONAL VIEW ENDS
& STAINLESS STEEL INTERIOR



■ 72" & 86 1/2" TALL UNITS OFFERED WITH UP TO 4 OPTIONAL ROWS OF SHELVES

■ 83" (SELF-CONTAINED) TALL UNIT OFFERED WITH UP TO 5 OPTIONAL ROWS OF SHELVES

STANDARD FEATURES

- DOE 2017 Compliant
- Remote Refrigeration
- Self-Contained Refrigeration
- Multi-Deck Air Curtain
- Modular Coil System - 5 Year Warranty
- Black Interior
- T5 Top Light
- 2" Black Vinyl Cart Bumper
- Solar Digital Thermometer
- Please Reference Color Chart for Choice of Standard Hussmann Paint and Finish Options
- ETL Listed / ETL Sanitation Listed
- Environmentally Safe Refrigerant

OPTIONAL FEATURES

- Curved Adjustable Shelves (Up To 5) with PTM (250lb max)
- Lights for Shelves with Remote Ballast (T5)
- Solid or View End
- Mirror Bright Stainless Steel on Interior of End Panels
- White or Stainless Steel Interior
- Back-Lighted Sign
- Thermostat
- Liquid Line Hand Valve
- Special Interior and Exterior Finishes
- Custom Lengths and Options
(Consult your Hussmann Sales Representative)

MODEL # RGDC - HFS

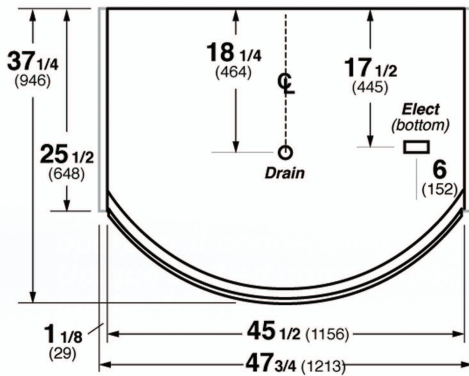

Electrical & Plumbing locations

SELF - CONTAINED

MODEL	L*	D	H	HP	VOLTS	AMPS	PLUG	WT	REFRIG.
RGDC24-72-HFS	47 3/4	37 1/4	86 1/2	1/2	208-240	11.0	14-30P	1200	404A

REMOTE - REFRIGERATED

MODEL	L*	D	H	BTU / HR	VOLTS	AMPS	EVAP. TEMP °F	PLUG	WT	REFRIG.
RGDC24-72-HFS	47 3/4	37 1/4	72	7820	208-240	4.0	20	Hardwire	1100	Verify
RGDC24-83-HFS	47 3/4	37 1/4	83	8280	208-240	7.5	20	Hardwire	1200	Verify

* LENGTHS INCLUDE END PANELS

RGDC 24-72-4SC Self Contained Deli Self Service

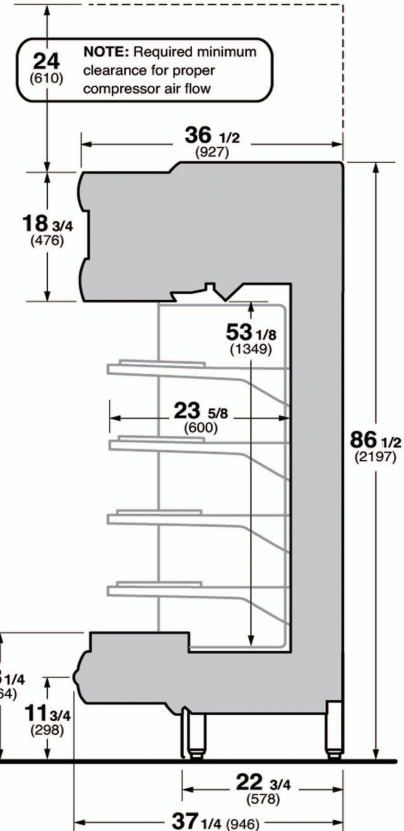

RGDC 24-83 Remote Deli Self Service

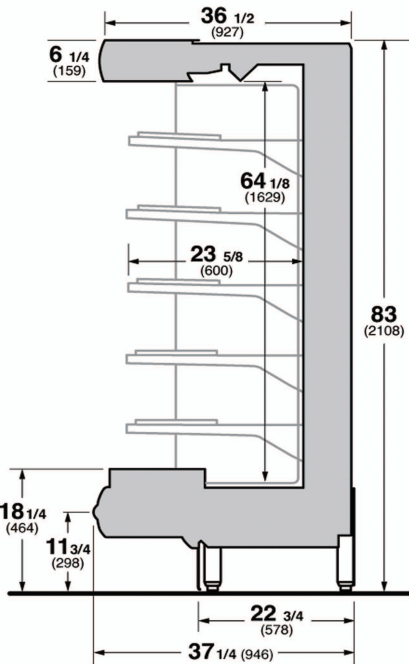

RGDC 24-72 Remote Deli Self Service

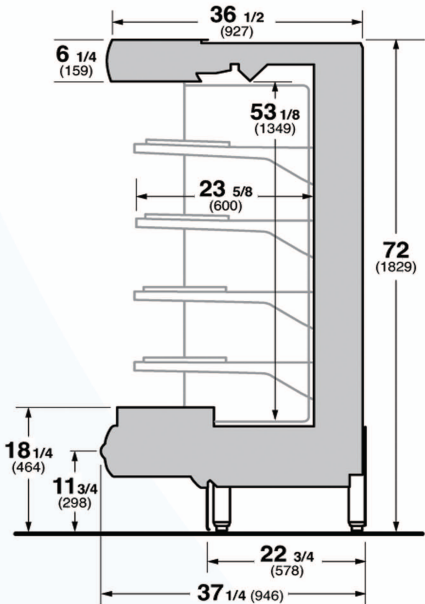

Conforms to UL Standard 471, and NSF Standard 7; Certified To CSA Standard C22.2 No.120



Hussmann refrigerated merchandisers configured for sale for use in the United States meet or surpass the requirements of the DOE 2017 energy efficiency standards

- For optimum performance, these merchandisers are designed for use in stores where ambient temperatures and humidity do not exceed 75 Degrees Fahrenheit and 55% R.H. Locate away from direct sunlight, rapid air currents and extreme temperature changes. Exposure to air currents from ceiling fans, air conditioning diffusers, ovens, etc. will disrupt the case air curtain and refrigerated zone. Refrigerated Displays are designed to maintain pre-chilled products. Adding or loading warm products above 41 Degrees Fahrenheit can affect the temperature in the entire cabinet.

RPI in line with its current policy reserves the right to change or revise specifications and product design in connection with any feature of our products. Such changes do not entitle the buyer to corresponding changes improvements, additions, or replacements for equipment previously sold or shipped.

CALL TOLL FREE: 800-525-3692 (609-714-2330)

FAX: 609-714-2331 www.rpiindustries.com

220 ROUTE 70, MEDFORD, NJ 08055