

MODEL # RI2 - HFS

SPECIFICATIONS

The Specialty Series RI2 creates an attention grabbing display for deli products, prepared foods, sandwiches or other medium temperature products. The low profile design places your merchandise within easy reach, while maintaining visibility throughout the footprint. To accent your case merchandising, the RI2 includes a non-refrigerated top display area. This can be used for complementary non-refrigerated items and to add color and visual interest to your footprint.



Available lengths: 98 1/4" 122 1/4" 146 1/4" 170 1/4" 194 1/4"

Available depths: 72"

Available heights: 55 3/4"



UNIT SHOWN WITH OPTIONAL
UPPER SHELVES

STANDARD FEATURES

- DOE 2017 Compliant
- Remote Refrigeration
- All Metal Construction
- Hussmann Standard Paint & Bumper Colors
(Consult Factory for Available Colors)
- (1) Row Canopy Lighting
- 18 1/8" Non-Refrigerated Top Display
- 27" Base Deck Display
- 5 7/8" Curved Plexiglass Perimeter
- 3" High Plexi Product Stop
- Center Air Discharge
- Hardwire Direct
- Listed in Accordance with UL 471
and NSF 7 Standards
- Floor Drain Required

OPTIONAL FEATURES

- Stainless Steel Exterior Finish
- Hussmann Optional Colors
(Consult Factory for Available Colors)
- Up to (2) Rows of Optional Shelves
 - 8" Angled Shelf
 - 12" Angled Shelf
- Lighting Under Shelves
(Consult Factory for All Available Options)
- 9 7/8" Curved Plexiglass Perimeter
- 6" High Plexi Product Stop

MODEL # RI2 - HFS

REMOTE - REFRIGERATED

MODEL	L*	D	H	BTU/HR	VOLTS	AMPS	EVAP. TEMP °F	PLUG	WT	REFRIG.
RI2 8'-HFS	98 1/4	72	55 3/4	1520	120	1.2	20	Hardwire	1200	Verify
RI2 10'-HFS	122 1/4	72	55 3/4	1520	120	1.8	20	Hardwire	1400	Verify
RI2 12'-HFS	146 1/4	72	55 3/4	1520	120	2.4	20	Hardwire	1500	Verify
RI2 14'-HFS	170 1/4	72	55 3/4	1520	120	3.0	20	Hardwire	1700	Verify
RI2 16'-HFS	194 1/4	72	55 3/4	1520	120	3.6	20	Hardwire	1900	Verify

* LENGTHS INCLUDE END PANELS

Note: Please use Hussmann's technical data sheets to get precise dimensions for all store layout purposes.

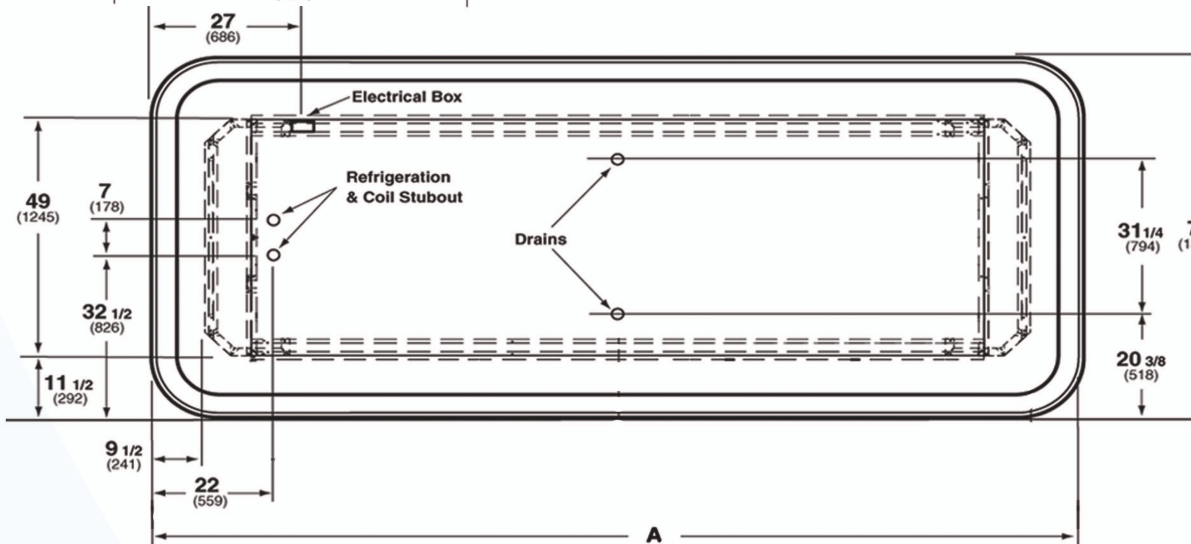
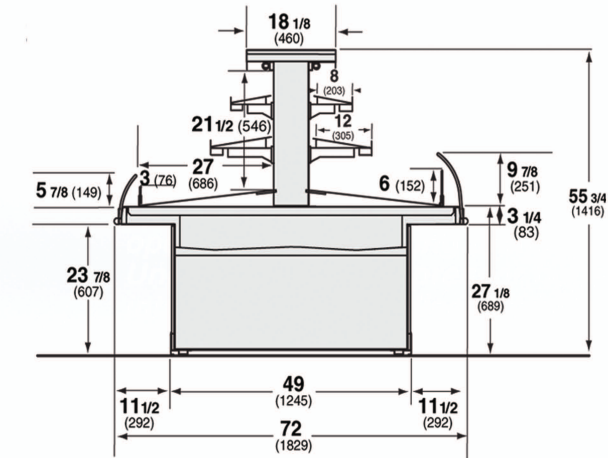

Electrical & Plumbing locations

Dimension	A
8 FT CASE	96 (2439)
10 FT CASE	120 (3049)
12 FT CASE	144 (3658)
14 FT CASE	168 (4268)
16 FT CASE	192 (4878)



Conforms to UL Standard 471,
and NSF Standard 7; Certified
To CSA Standard C22.2 No.120



Hussmann refrigerated merchandisers configured for sale for use in the United States meet or surpass the requirements of the DOE 2017 energy efficiency standards

1. For optimum performance, these models are designed for use in air-conditioned stores where temperature and humidity are maintained at 75°F and 55% R.H. Locate case away from direct sunlight, rapid air currents and extreme temperature changes. Case is designed for holding pre-chilled product only.

RPI in line with its current policy reserves the right to change or revise specifications and product design in connection with any feature of our products. Such changes do not entitle the buyer to corresponding changes improvements, additions, or replacements for equipment previously sold or shipped.

CALL TOLL FREE: 800-525-3692 (609-714-2330)

FAX: 609-714-2331 www.rpiindustries.com

220 ROUTE 70, MEDFORD, NJ 08055