

MODEL # SCBD

SPECIFICATIONS

The Lexington Deli SCBD Series is a refrigerated deli display case with a choice of standard grade laminate exterior ends and with fixed curved front insulated glass.

Available lengths: 36" 48" 60" 72" 96"

Available depths: 35 3/4"

Available heights: 50"



STANDARD FEATURES

- Self-Contained Refrigeration
- Fixed Curved Front Insulated Glass
- Standard Grade Laminate Exterior
- Black Base
- Mirrored Interior Vision End Panels
- LED Top Canopy Light
- (2) Stainless Steel Shelves with LED Lights
- See-Through Mirrored Rear Sliding Doors
- Stainless Steel Deck Pan
- Thermometer
- 8' Cord and Plug
- ETL Listed in Accordance with UL 471 and NSF 7 Standards
- Environmentally Safe Refrigerant
- 1 Year Parts and Labor Warranty
- Built-In Condensate Evaporator - 3', 4', 5' & 6' Units Only
- Floor Drain Required - 8' Units
- 5 Year Compressor Warranty

OPTIONAL FEATURES

- Stainless Steel Exterior Finish
 - #4 #6 #8
- Special Laminates
- Wood Veneers (Unfinished)
- Wood Veneers (Stained & Sealed)
- Miscellaneous Trim
- Brass Trim and Hardware
- Wire Shelves
 - Brass White Black Chrome
- Casters (Increases Height by 4")
- Adjustable Legs (Consult Factory for Sizes)
- Mirrored Polished Stainless Steel Interior Ends (#8 Finish)
- Insulated Glass Vision End Panels
- Rear Door Locks
- 8" Wrap Board

NOTE: EXCEEDS STANDARD 36" DOOR OPENING FOR INSTALLATION ACCESS



CALL TOLL FREE: 800-525-3692 (609-714-2330)

FAX: 609-714-2331 www.rpiindustries.com

220 ROUTE 70, MEDFORD, NJ 08055

MODEL # SCBD

SELF - CONTAINED

MODEL	L	D	H	HP	VOLT	AMP	PLUG	WT	REFRIG.
SCBD36R	36	35 3/4	50	1/3	115	9.4	5-15P	600	134A
SCBD48R	48	35 3/4	50	1/3	115	9.4	5-15P	700	134A
SCBD60R	60	35 3/4	50	1/3	115	9.5	5-15P	800	134A
SCBD72R	72	35 3/4	50	1/2	115	14.0	5-20P	900	134A
SCBD96R	96	35 3/4	50	1/2	115	14.9	5-20P	1100	134A

REMOTE - REFRIGERATED

MODEL	BTU @ 20° F	VOLT	AMP	PLUG	WT	REFRIG.
SCBD36R-RR	2360	115	1.6	5-15P	557	Verify
SCBD48R-RR	2360	115	1.7	5-15P	640	Verify
SCBD60R-RR	2360	115	1.8	5-15P	740	Verify
SCBD72R-RR	4140	115	2.5	5-15P	840	Verify
SCBD96R-RR	4140	115	2.5	5-15P	1050	Verify

GLYCOL

MODEL	BTU @ 20° F	VOLT	AMP	PLUG	WT	GPM	REFRIG.
SCBD36R-RR-GL	2360	115	1.6	5-15P	640	.5	GLYCOL
SCBD48R-RR-GL	2360	115	1.7	5-15P	640	.5	GLYCOL
SCBD60R-RR-GL	2360	115	1.8	5-15P	740	.5	GLYCOL
SCBD72R-RR-GL	4140	115	2.5	5-15P	840	1.0	GLYCOL

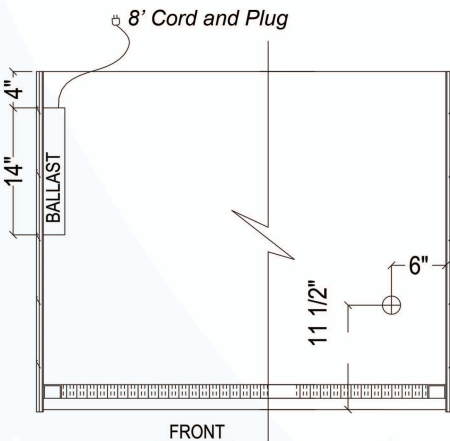
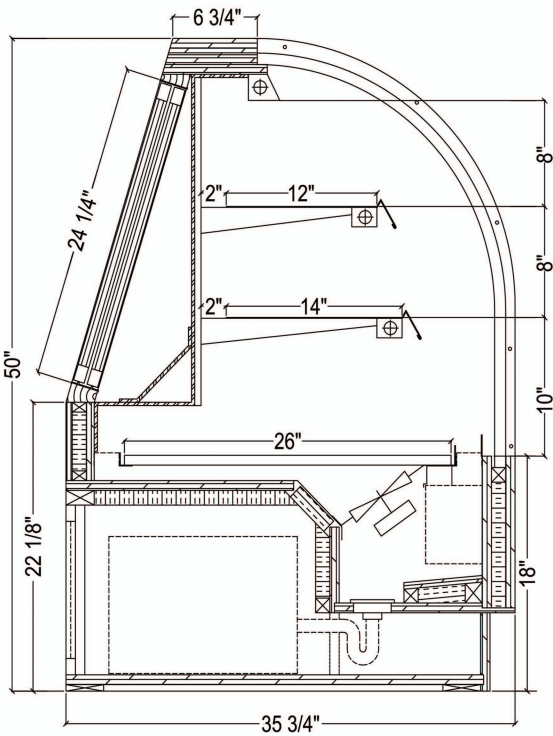

Electrical & Plumbing locations



Conforms to UL Standard 471,
 and NSF Standard 7; Certified
 To CSA Standard C22.2 No.120



RPI refrigerated merchandisers configured for sale for use in the United States meet or surpass the requirements of the DOE 2017 energy efficiency standards

1. SCBD96R requires a floor drain. No evaporation pan available.
2. All Remote and Glycol units must be run to a floor drain at time of installation.
3. The SCBD merchandiser is designed for use in stores where temperature and humidity do not exceed 75 degrees F and 55% R. H. Locate away from direct sunlight, rapid air currents and extreme temperature changes. Any adverse field conditions stated above will void warranty.

RPI in line with it's current policy to continually improve it's product reserves the right to change materials and specifications without notice.

CALL TOLL FREE: 800-525-3692 (609-714-2330)
 FAX: 609-714-2331 www.rpiindustries.com
 220 ROUTE 70, MEDFORD, NJ 08055