

3-TIER SQUARED HOT DISPLAY WITH REAR FEED

SPECIFICATIONS

Patented technology is designed to allow hot air convection, which enables the individual zones to be controlled, maintaining the quality of the product. The innovative technology of Flexeserve Zone® gives the versatility of tailoring the hot food offerings, reducing product waste from the ability to turn zones on or off predicated upon the time of day and customer demands! These Models feature rear hinged access doors for easy operator loading.

- Available lengths: 23 5/8" 39 3/8"
 Available depths: 28"
 Available heights: 54 3/8"



STANDARD FEATURES

- Individually controlled temperature zones
- Energy efficient LED lighting in all zones
- Rear Hinged Doors With Mirrored Interior
- Fan Guards Included
- Squared top canopy
- Brushed stainless steel exterior top canopy & lower front valance
- Squared double glazed glass end panels
- Black glass display shelves
- Stainless steel shelf edges
- Clear ticket strips, shelf risers & ticket strips
- Smart Controller
- (4) 4" Casters

Note – For the FXZNA60S3S-RF model, there is an option for rear door to be right or left hinged. This will need to be verified at the time of order.
Note – Optional night blind is designed to close the unit down when unit is not in use.
Note – Product can be stacked on shelves but cannot reach the top; air must be able to circulate over product.
Note – Units must be accessible from the rear for servicing

MARKETING ACCESSORIES

- Angled Merchandising Insert (Order 1 to fill the shelf, 2 for FXZNA10S3S-RF)
- Merchandising Divider (Recommended for use with Angled Inserts)
- Merchandising Tray
 - FXZNA60S3S-RF (2 to fill the shelf)
 - FXZNA10S3S-RF (4 to fill the shelf)

CALL TOLL FREE: 800-525-3692 (609-714-2330)
 FAX: 609-714-2331 www.rpiindustries.com
 220 ROUTE 70, MEDFORD, NJ 08055

OPTIONAL FEATURES

- #8 Mirrored polished stainless steel for **top fascia* and lower valance***
- Exterior standard colors for top fascia and lower valance (See RPI Color Chart)
- Exterior custom colors for top fascia and lower valance (Consult factory)
- Exterior with custom graphics package (Consult factory)
- Night Blind



FXZNA10S3S-RF model shown

- Merchandising Rack - Narrow (Recommended for use with Merchandising Trays)
- Merchandising Rack - Standard (Recommended for use with Merchandising Trays)
- Black Metal Condiment Basket (hangs from ticket edge)
- Acrylic Condiment Basket (Recommended hang from riser)
- Variety box of recommended packaging samples

3-TIER SQUARED HOT DISPLAY WITH REAR FEED

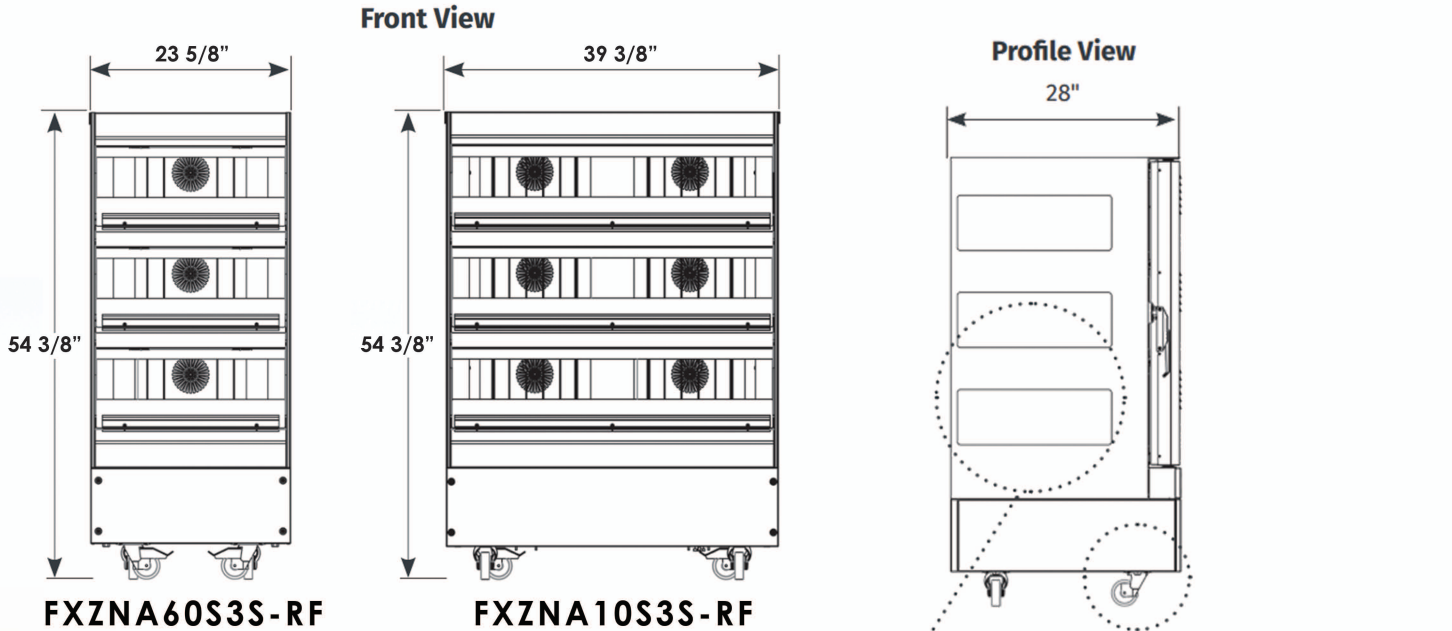

Shelf Footprint & Merchandizing Volume*

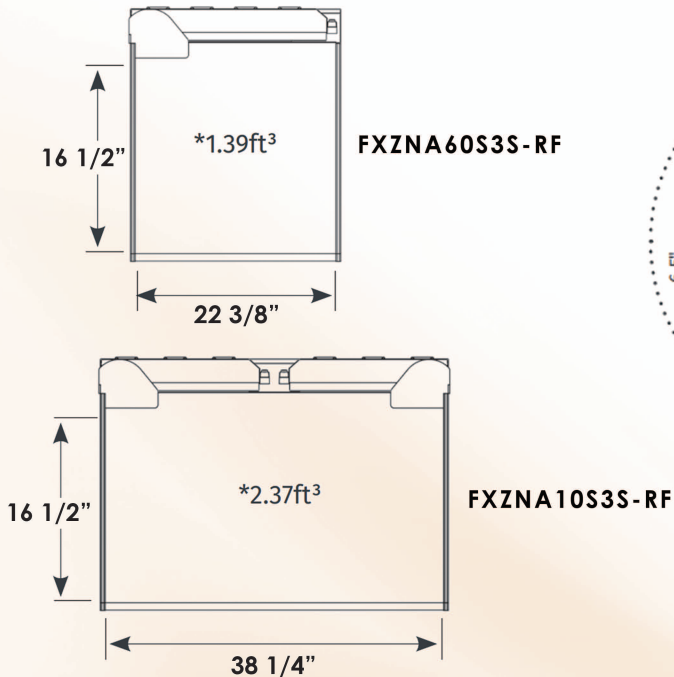

Interior Zone Dimensions

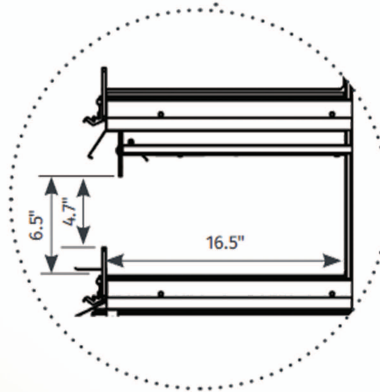

Foot Height & Power Cord Height / Length*

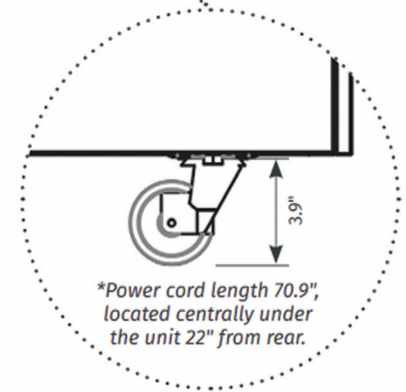

PLUG CONFIGURATION

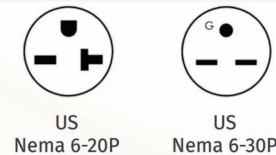

| MODEL | L | D | H | VOLT | AMP | PLUG | WT |
|---------------|---------|-----|---------|----------------------|------|-------|-----|
| FXZNA60S3S-RF | 23 5/8" | 28" | 54 3/8" | SINGLE PHASE 208/230 | 15.2 | 6-20P | 432 |
| FXZNA10S3S-RF | 39 3/8" | 28" | 54 3/8" | SINGLE PHASE 208/230 | 21.6 | 6-30P | 628 |

Note: A 2" clearance is required behind the unit for ventilation.

USA Patent Number - 9,462,897 B2



Conforms to UL Standard 197, and NSF Standard 4; Certified To CSA Standard C22.2 No.109

RPI in line with its policy to continually improve its products reserves the right to change materials and specifications without notice.

CALL TOLL FREE: 800-525-3692 (609-714-2330)

FAX: 609-714-2331 www.rpiindustries.com

220 ROUTE 70, MEDFORD, NJ 08055