

LIFT FRONT GLASS MODEL # SCLLB

SPECIFICATIONS

The LaRond SCLLB Series is a refrigerated display case with a choice of standard grade plastic laminate exterior ends and with lift-up curved front tempered glass.

Available in refrigerated or non-refrigerated.

Available lengths: 47" * 59" 71" 93 1/8" *
 Available depths: 35 3/4"
 Available heights: 50"



STANDARD FEATURES

- Self-Contained Refrigeration
- Lift-Up Curved Front Tempered Glass
- Standard Grade Laminate Exterior
- Black Base
- Mirrored Interior Vision End Panels
- White Laminated Deck
- LED Top Canopy Light
- (3) Tempered Glass Shelves with LED Lights
- See-Through Mirrored Rear Sliding Doors
- Front Air Chaser
- Thermometer
- 8' Cord and Plug
- ETL Listed in Accordance with UL 471 and NSF 7 Standards
- Environmentally Safe Refrigerant
- 1 Year Parts and Labor Warranty
- Built-In Condensate Evaporator (No Floor Drain Required)
- 5 Year Compressor Warranty

OPTIONAL FEATURES

- Remote Refrigeration (floor drain required)
- Lift-Up Curved Front Insulated Glass (4' Units Only, Consult Factory)
- Stainless Steel Exterior Finish
 - #4 #6 #8
- Special Laminates
- Wood Veneers (Unfinished)
- Wood Veneers (Stained & Sealed)
- Miscellaneous Trim
- Brass Trim and Hardware
- Wire Shelves
 - Brass White Black Chrome
- Casters (Increases Height by 4")
- Adjustable Legs (Consult Factory for Sizes)
- Mirrored Polished Stainless Steel Interior Ends (#8 Finish)
- Stainless Steel Laminated Deck
- Insulated Glass Vision End Panels
- Front Glass Locks
- Rear Door Locks
- 8" Wrap Board

LIFT FRONT GLASS MODEL # SCLLB

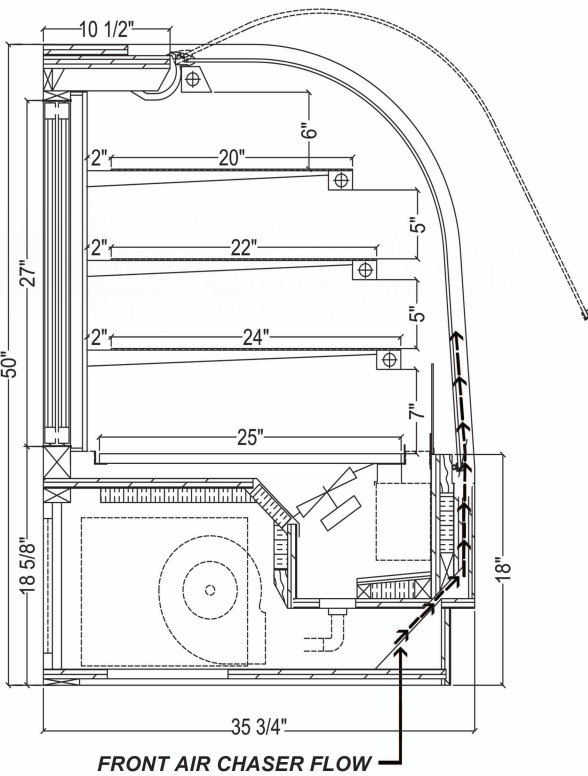

SELF - CONTAINED

MODEL	L	D	H	HP	VOLT	AMP	PLUG	WT	REFRIG.
SCLLB60R	59	30-35 3/4	50	1/2	115	10.5	5-15P	750	134A
SCLLB96R	93 1/8	30-35 3/4	50	1/2	115	16.0	5-20P	1100	134A

AMBIENT

MODEL	L	D	H	VOLT	AMP	PLUG	WT
SCLLB48D	47	35 3/4	50	115	.60	5-15P	450
SCLLB60D	59	35 3/4	50	115	.70	5-15P	550
SCLLB72D	71	35 3/4	50	115	.80	5-20P	700
SCLLB96D	93 1/8	35 3/4	50	115	1.01	5-20P	875

REMOTE - REFRIGERATED

MODEL	BTU @ 20° F	VOLT	AMP	PLUG	WT	REFRIG.
SCLLB48R-RR	2360	115	2.6	5-15P	540	Verify
SCLLB60R-RR	2360	115	2.8	5-15P	640	Verify
SCLLB72R-RR	4140	115	2.9	5-15P	790	Verify
SCLLB96R-RR	4140	115	4.63	5-15P	1010	Verify

* 448a refrigeration available at no additional cost - please specify

Electrical & Plumbing locations

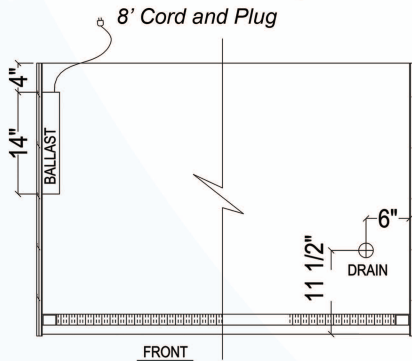

Conforms to UL Standard 471,
and NSF Standard 7; Certified
To CSA Standard C22.2 No.120



RPI refrigerated merchandisers configured for sale for use in the United States meet or surpass the requirements of the DOE 2017 energy efficiency standards

1. All Remote and Glycol units must be run to a floor drain at time of installation.
2. The SCLLB merchandiser is designed for use in stores where temperature and humidity do not exceed 75 degrees F and 55% R.H. Locate away from direct sunlight, rapid air currents and extreme temperature changes. Any adverse field conditions stated above will void warranty.

RPI in line with it's current policy to continually improve it's product reserves the right to change materials and specifications without notice.

CALL TOLL FREE: 800-525-3692 (609-714-2330)
 FAX: 609-714-2331 www.rpiindustries.com
 220 ROUTE 70, MEDFORD, NJ 08055

RPI INDUSTRIES, INC. v5_30_23