

ANNAPOLIS MODEL # SCXAD

SPECIFICATIONS

The Express Annapolis Euro Deli SCXAD Series is a refrigerated deli display case designed with a mezzanine shelf within the refrigerated product zone. Available with a choice of standard grade plastic laminate exterior ends and with lift-up curved front tempered glass for easy cleaning and stocking.



Available lengths: 51 1/8" 63 1/8" 75 1/4" 99 1/4"

Available depths: 43 7/8"

Available heights: 52 1/4"

STANDARD FEATURES

- Remote Refrigeration
- Lift-Up Curved Front Tempered Glass
- Heavy Gauge Steel Frame Base Construction
- Standard Grade Laminate Exterior
- Stainless Steel Back
- Black Base
- Rear Work Ledge with Zip Lite Cutting Board
- Brushed Aluminum Interior Ends with 3/8" Plexiglass Vision End Panels
- Stainless Steel Perforated Interior Back Panel
- LED Top Canopy Light
- (1) Refrigerated Mezzanine Glass Shelf with LED Light
- Clear Plexi Rear Sliding Doors
- Stainless Steel Deck Pan
- Front Air Chaser
- Thermometer
- 8' Cord and Plug
- ETL Listed in Accordance with UL 471 and NSF 7 Standards
- Environmentally Safe Refrigerant
- 1 Year Parts and Labor Warranty
- Floor Drain Required
- 5 Year Compressor Warranty

OPTIONAL FEATURES

- Stainless Steel Exterior Finish
 - #4 #6 #8
- Special Laminates
- Wood Veneers (Unfinished)
- Wood Veneers (Stained & Sealed)
- Miscellaneous Trim
- Brass Trim and Hardware
- Black Styrene Step Sham
- Stainless Steel Step Sham
- Casters (Increases Height by 4")
- Adjustable Legs (Consult Factory for Sizes)
- Mirrored Polished Stainless Steel Interior Ends (#8 Finish)
- Mirrored Polished Stainless Steel Perforated Interior Back Panel (#8 Finish)
- Mirrored Plexi Rear Sliding Doors
- Corian® Rear Work Ledge
- Zodiac® Rear Work Ledge
- Tempered Glass Vision End Panels
 - 1/2 Glass End Panels Full Glass End Panels
- Front Glass Locks
- Rear Door Locks
- Scale Platform and Plug

NOTE: EXCEEDS STANDARD 36" DOOR OPENING FOR INSTALLATION ACCESS



CALL TOLL FREE: 800-525-3692 (609-714-2330)

FAX: 609-714-2331 www.rpiindustries.com

220 ROUTE 70, MEDFORD, NJ 08055

RPI INDUSTRIES, INC. v8_31_17

ANNAPOLIS MODEL # SCXAD

REMOTE - REFRIGERATED

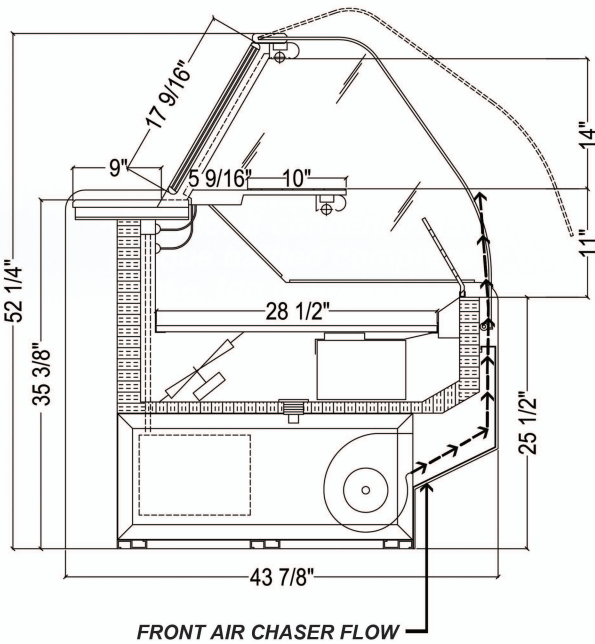

MODEL	BTU @ 20° F	VOLT	AMP	PLUG	WT	REFRIG.
SCXAD48R-RR	2360	115	2.0	5-15P	540	Verify
SCXAD60R-RR	2360	115	2.0	5-15P	750	Verify
SCXAD72R-RR	4140	115	2.5	5-15P	800	Verify
SCXAD96R-RR	4140	115	3.0	5-15P	900	Verify

GLYCOL

MODEL	BTU @ 20° F	VOLT	AMP	PLUG	WT	GPM	REFRIG.
SCXAD48R-RR-GL	2360	115	2.0	5-15P	540	.59	GLYCOL
SCXAD60R-RR-GL	2360	115	2.0	5-15P	750	.59	GLYCOL
SCXAD72R-RR-GL	4140	115	2.5	5-15P	800	1.0	GLYCOL

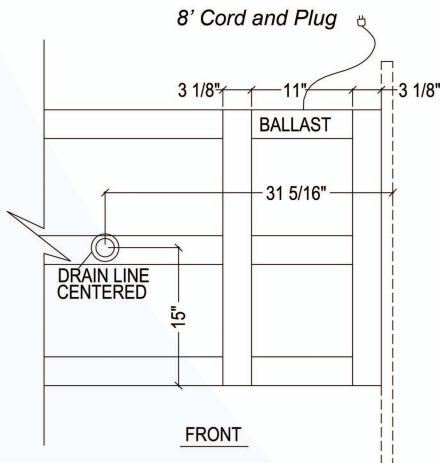

Electrical & Plumbing locations



Conforms to UL Standard 471,
and NSF Standard 7; Certified
To CSA Standard C22.2 No.120



RPI refrigerated merchandisers configured for sale for use in the United States meet or surpass the requirements of the DOE 2017 energy efficiency standards

1. SCXAD96R Requires a floor drain. No evaporation pan available.
2. All Remote and Glycol Units must be run to a floor drain at time of installation.
3. The SCXAD merchandiser is designed for use in stores where temperature and humidity do not exceed 75 degrees F and 55% R.H. Locate away from direct sunlight, rapid air currents and extreme temperature changes. If rear doors are removed, temperature will not remain stable. Any adverse field conditions stated above will void warranty.

RPI in line with it's current policy to continually improve it's product reserves the right to change materials and specifications without notice.

CALL TOLL FREE: 800-525-3692 (609-714-2330)
 FAX: 609-714-2331 www.rpiindustries.com
 220 ROUTE 70, MEDFORD, NJ 08055

RPI INDUSTRIES, INC. v1.13