

MODEL # SCRFC (78" HIGH UNIT)

SPECIFICATIONS

The Bandit Air Screen SCRFC Series is a grab and go style refrigerator. The self-contained refrigeration system includes digital controls allowing unit to engage in minimal defrost cycles. Front mounted red indicator light alerts operator if condensing unit requires cleaning. Unique baffled compressor housing for front air intake, top rear air discharge reducing noise levels plus zero clearance from wall installation. Unit comes standard with 4 adjustable extra deep shelves and top canopy light. Optional lights underneath shelving available in energy efficient LED lighting.

Available lengths: 36" 48" 60" 72"

Available depths: 32 5/8"

Available heights: 78"



STANDARD FEATURES

- DOE 2017 Compliant
- Self-Contained Refrigeration
- Metal Frame Base Construction with Lift-Out Black Louvered Air Grill for Easy Access to Compressor
- Standard Grade Laminate Exterior
- T-Mold Edge Protection
- Brushed Aluminum Interior Ends
- Stainless Steel Perforated Interior Back Panel
- LED Top Canopy Light
- (4) Adjustable Stainless Steel Extra Deep Shelves for Maximum Capacity
- Removable Stainless Steel Deck Pan with Hemmed Edge to Contain Spills
- Electronic Digital Control and Defrost Termination
- Red Indicator Light Alerts Operator if Condenser Requires Cleaning
- Digital Temperature Display
- Unique Internal Baffle Design for Compressor Noise Reduction
- Front Air Intake with Top Rear Air Discharge for Zero Clearance
- Easy Slide-Out Condensing Unit (4', 5' & 6' Units)
- 8' Cord and Plug
- Conforms to NSF STD 7 Type II Refrigeration
- Environmentally Safe Refrigerant
- 1 Year Parts and Labor Warranty
- Floor Drain Required
- 5 Year Compressor Warranty

OPTIONAL FEATURES

- Green Screen
- Remote Refrigeration
- Stainless Steel Exterior Finish with Standard T-Molding
 - #4 #6 #8
- Special Laminates
- Wood Veneers (Stained & Sealed)
- Miscellaneous Trim
- Energy Efficient LED Lighting Below Shelves
- Wire Shelves
 - Brass White Black Chrome
- Mirrored Polished Stainless Steel Shelves (#8 Finish)
- Casters (Increases Height by 4")
- Adjustable Legs (Consult Factory for Sizes)
- Powder Coated Interior Back Panel and Hardware
 - Black White Custom Color
- Mirrored Polished Stainless Steel Interior Ends (#8 Finish)
- Mirrored Polished Stainless Steel Perforated Interior Back Panel (#8 Finish)
- Finished Back with Black Air Grill
- Stainless Steel Louvered Air Grill
- Solid Insulated Rear Sliding Doors
- See-Through Insulated Rear Sliding Doors
- Removable Locking Security Panels
- Energy Efficient #23 Pull-Down Night Curtain
- Tie-In Strips for Interconnection of Units
- Thermometer

CALL TOLL FREE: 800-525-3692 (609-714-2330)

FAX: 609-714-2331 www.rpiindustries.com

220 ROUTE 70, MEDFORD, NJ 08055



MODEL # SCRFC (78" HIGH UNIT)

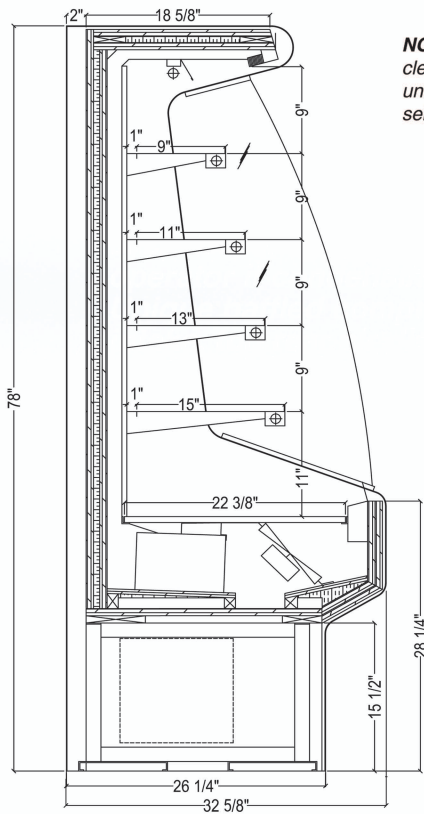

NOTE: A minimum of 18" clearance needed above unit for air discharge for self contained units.

SELF - CONTAINED

MODEL	L	D	H	HP	VOLT	AMP	PLUG	WT	REFRIG.
SCRFC3678R	36	32 3/8	78	1/2	115	12.8	5-20P	675	134A
SCRFC4878R	48	32 3/8	78	3/4	115/208-230 4 wire	11.4	L14-30P	900	404A
SCRFC6078R	60	32 3/8	78	1 1/4	115/208-230 4 wire	12.4	L14-30P	1020	404A
SCRFC7278R	72	32 3/8	78	1 1/4	115/208-230 4 wire	12.5	L14-30P	1150	404A

AMBIENT

MODEL	L	D	H	VOLT	AMP	PLUG	WT
SCRFC3678D	36	32 3/8	78	115	0.40	5-15P	625
SCRFC4878D	48	32 3/8	78	115	0.52	5-15P	800
SCRFC6078D	60	32 3/8	78	115	0.65	5-15P	920
SCRFC7278D	72	32 3/8	78	115	0.78	5-15P	1050

REMOTE - REFRIGERATED

MODEL	BTU @ 20°F	VOLT	AMP	PLUG	WT	REFRIG.
SCRFC3678R-RR	4140	115	1.32	5-15P	625	Verify
SCRFC4878R-RR	7470	115	1.86	5-15P	800	Verify
SCRFC6078R-RR	9960	115	2.00	5-15P	920	Verify
SCRFC7278R-RR	9960	115	2.50	5-15P	1050	Verify

GLYCOL

MODEL	BTU @ 20°F	VOLT	AMP	PLUG	WT	GPM	REFRIG.
SCRFC3678R-RR-GL	4140	115	1.32	5-15P	625	1.0	GLYCOL
SCRFC4878R-RR-GL	7470	115	1.86	5-15P	800	2.0	GLYCOL
SCRFC6078R-RR-GL	9960	115	2.00	5-15P	920	2.5	GLYCOL
SCRFC7278R-RR-GL	9960	115	2.50	5-15P	1050	2.5	GLYCOL

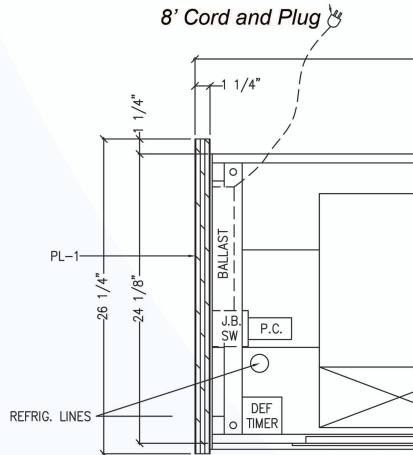

Electrical & Plumbing locations

RPI refrigerated merchandisers configured for sale for use in the United States meet or surpass the requirements of the DOE 2017 energy efficiency standards

1. All Self-Contained, Remote and Glycol Units must be run to a floor drain at time of installation.
2. Refrigeration System is designed so air will flow front to rear. Unobstructed air flow must be maintained to ensure unit performance and maintain warranty.
3. The SCRFC merchandiser is designed for use in stores where ambient temperatures and humidity do not exceed 80 Degrees Fahrenheit and 60% R.H. Locate away from direct sunlight, rapid air currents and extreme temperature changes. Exposure to air currents from ceiling fans, air conditioning diffusers, ovens, etc. will disrupt the case air curtain and refrigerated zone. Refrigerated Displays are designed to maintain pre-chilled products. Adding or loading warm products above 41 Degrees Fahrenheit can affect the temperature in the entire cabinet. Any adverse field conditions stated above will void warranty.

RPI in line with its policy to continually improve its products reserves the right to change materials and specifications without notice.

CALL TOLL FREE: 800-525-3692 (609-714-2330)
 FAX: 609-714-2331 www.rpiindustries.com
 220 ROUTE 70, MEDFORD, NJ 08055

RPI INDUSTRIES, INC. v10_13_20