

GATHER TABLES

PROJECT: _____

ITEM: _____ QUANTITY: _____

MODEL # CASCADE H 72

SPECIFICATIONS

Hi stone top with water fall ends and 5" apron edge, laminate plate / utensil sill, raised single induction area with remote control panel with off/on, display and 20 power levels, closed millwork base, Formica or Wilson Art standard laminate matte finish exterior, 115V/60/1, 6 amps, 8' cord, NEMA 5-15P.

Available lengths: 72"

Available depths: 30"

Available heights: 34"

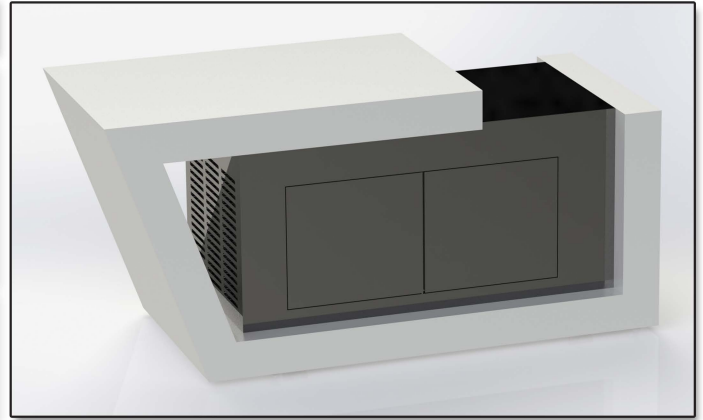

STANDARD FEATURES

- Hi stone top, apron & waterfall ends
- Hi stone (available in 6 colors)
- Standard plastic laminate matte finish exterior
- Laminate plate/utensil sill
- Raised induction area with (1) induction unit
- Concealed control with 20 power levels with display
- Hinged access panels to controls & electric
- Satin chrome knob-pulls
- Adjustable levelers
- 115v / 60 / 1, 6amps, 15 amp dedicated circuit required
- 8' cord and NEMA 5-15P plug

OPTIONAL FEATURES

- 3" Casters
- Lock per door
- Premium laminate
(Must specify brand name, number and color, contact factory for price.)

Some options may change electrical requirements.

Note: Units designed for warming not cooking.

Note: Induction pans should have lids or covers to maintain proper food temperature.

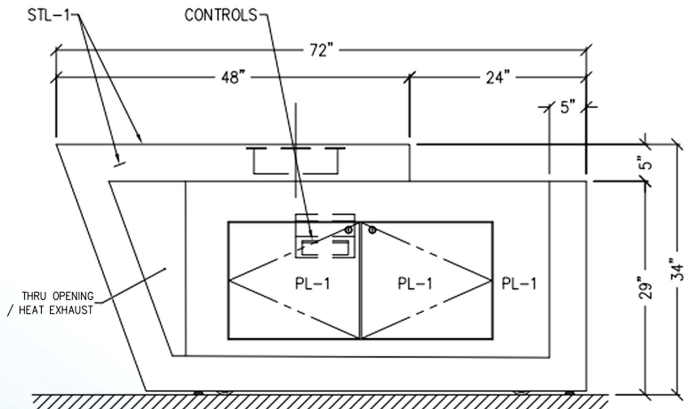
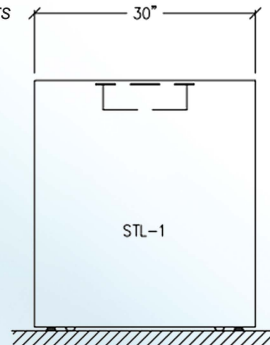

Electrical Locations

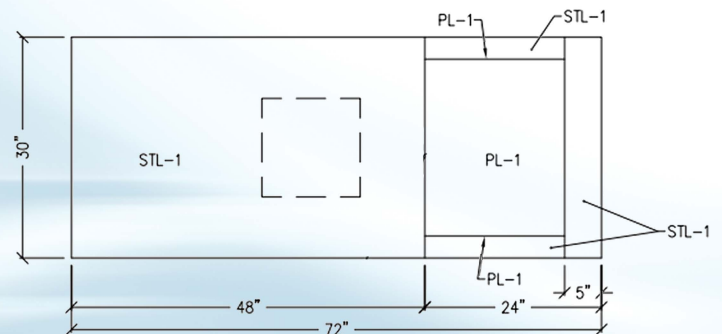
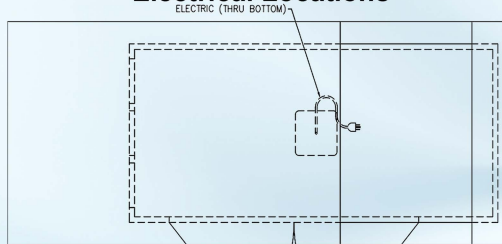

RPI in line with its policy to continually improve its products reserves the right to change materials and specifications without notice.

CALL TOLL FREE: 800-525-3692 (609-714-2330)

FAX: 609-714-2331 www.rpiindustries.com

220 ROUTE 70, MEDFORD, NJ 08055

