

# GATHER TABLES

PROJECT: \_\_\_\_\_

ITEM: \_\_\_\_\_ QUANTITY: \_\_\_\_\_

## MODEL # CONVENE H 96

### SPECIFICATIONS

Hi stone top with 3" integrated angled apron edge, area's for plate's / utensils on top, single induction area with remote control panel with off/on, display and 20 power levels, closed millwork pedestal base, hinged access panels to controls, Formica or Wilson Art standard laminate matte finish exterior, 115V/60/1, 6 amps, 15 amp dedicated circuit required, 8' cords with NEMA 5-15P.

Available lengths:  96"

Available depths:  30"

Available heights:  34"

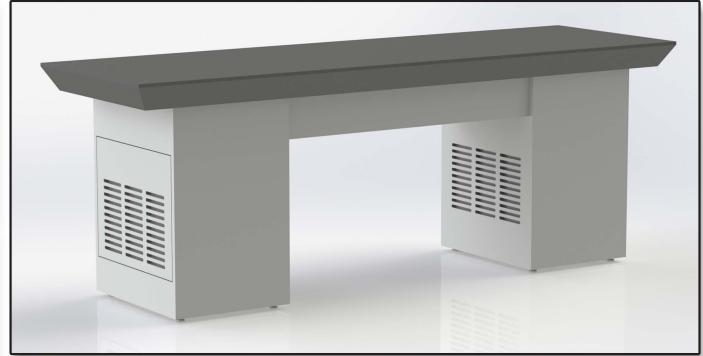

### STANDARD FEATURES

- Hi stone top with 3" integrated angled apron edge
- Hi stone (available in 6 colors)
- (1) induction unit included
- Standard plastic laminate matte finish exterior
- Area for plates / utensils on top
- Remote control panel 20 power levels with display
- Closed millwork pedestal bases with storage
- Adjustable shelf
- Hinge access panel to control panel and storage
- Adjustable levelers
- 115v / 60 / 1, 6 amps, 15 amps dedicated circuit required
- Ventilation slots
- Satin chrome knob-pull

### OPTIONAL FEATURES

- Add (1) induction unit 6 amps
- Add (2) induction units 6 amps each (additional 15 amps dedicated circuit required)
- Add (3) induction units 6 amps each (additional 15 amps dedicated circuit required)
- Lock per door
- Premium laminate (Must specify brand name, number and color, contact for price.)

Note: Some options may impact electrical requirements.

**Note: Units designed for warming not cooking**

Note: Induction pans should have lids or covers to maintain proper food temperature.

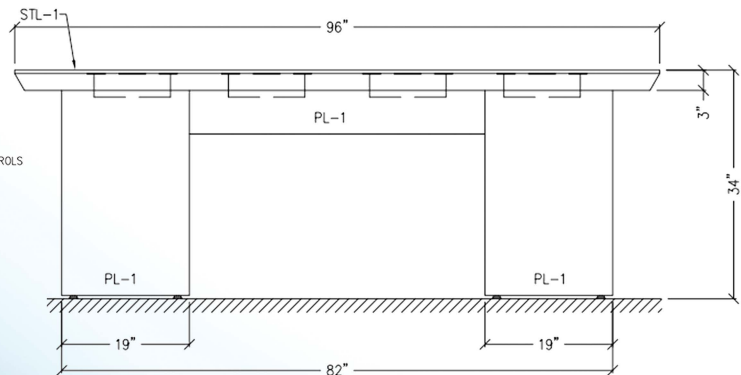
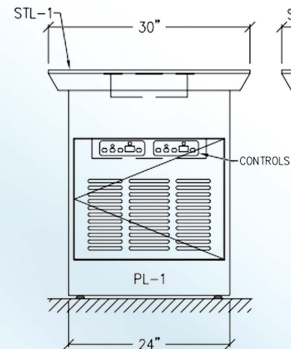

### Electrical Locations

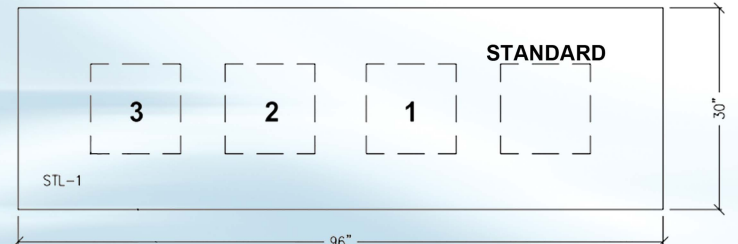
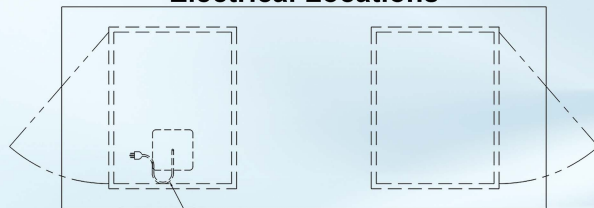

RPI in line with its policy to continually improve its products reserves the right to change materials and specifications without notice.

CALL TOLL FREE: 800-525-3692 (609-714-2330)

FAX: 609-714-2331 [www.rpiindustries.com](http://www.rpiindustries.com)

220 ROUTE 70, MEDFORD, NJ 08055

